



Enterprise Dynamics Tutorial

Enterprise Dynamics 10

Written by: InControl Simulation Solutions

Jaap Bijzerweg 21A

3446 CR Woerden

The Netherlands

www.incontrolsim.com

Date: 19/09/2022 15:06

Version: 10



Preface

If you want to drive a car, you are legally required to have a driving license. This demonstrates that you have learned how to control a vehicle and that you are not a major threat to other road users. Equally, nobody would expect to be able to learn to drive a car simply by reading the manual supplied in the glove box.

As far as simulation software - with its extensive possibilities - is concerned, there is no driving license. But here too training is a prerequisite to understanding the software and its application to simulation problems. To make an analogy with the manual supplied with a new car: merely flipping through the pages is not likely to be sufficient to learn how to actually drive the car.

Enterprise Dynamics® (ED) from InControl Simulations Solutions is a software program for discrete event simulation. The software is supplied with an extensive online help system. However, the demand arose from beginners - especially in the educational field - for a more structured step-by-step approach that would help them to learn the first principles of Enterprise Dynamics quickly while working alone.

The result is this Tutorial and it represents a first step to fulfilling this demand. The Tutorial covers a significant part of Enterprise Dynamics. It teaches you the basic skills to create your own simulation model and interpret the results.

A word of thanks goes to all the people, who have contributed to the development of this tutorial, and our users who have made comments in how to improve our tutorial and help system.

We invite you to forward comments about this tutorial or the software, suggestions for improvement etc. to Support@incontrolsim.com.

The Enterprise Dynamics Development and Support team and the Enterprise Dynamics Training & Education team.

1 Table of Contents

1.	Table of Contents	1-2
2.	Tutorial Layout	3-4
2.1.	The learning perspective	3-4
2.2.	Notation	3-4
2.3.	Tutorial Structure	3-4
2.4.	Learning Simulation	3-4
3.	Enterprise Dynamics's Background	5
4.	Getting Familiar with Enterprise Dynamics	6-9
4.1.	Starting Enterprise Dynamics	6-9
4.2.	The window sections	6-9
4.3.	The menu structure	6-9
4.4.	Structure of the library and the model	6-9
5.	Model Building Basics	10
5.1.	Dragging atoms into the model	10-13
5.2.	The Channels	14-18
6.	Analyzing the Results	19-21
6.1.	Techniques to measuring the results	21
6.2.	Measuring the results	21-32
7.	Playing with Strategies	33
7.1.	Adjusting the input strategy	34
7.2.	Changing the Queue Discipline	34-35
7.3.	Adjusting the Send to Statement	35
8.	More Atoms from Assembler to Unpack	36-39
9.	Enterprise Dynamics and Excel	40
9.1.	The bank	40-41
9.2.	The link with Excel	41-42
9.3.	Writing data to Excel	43
9.4.	Reading data from Excel into Enterprise Dynamics	43-44
9.5.	To pool or not to pool?	44-45
10.	The Human Resource	46
10.1.	Getting started with the Human Resource	46-49

10.2. Moving in the model's dimension	49-50
10.3. Walking Free Movement	50-51
10.4. Networks in general	52-53
10.5. Walking along a network	53-54
10.6. Allocation of priorities	54-55
10.7. More Human Resource options	55
11. The Transporter	56
11.1. Functionalities of the Transporter atoms	56
11.2. Working with the Transporter	56-58
11.3. The (Advanced) Transporter in the network	58-60
11.4. The connection between Dispatcher, Advanced Transporter and Destinator	60-63
11.5. Load and unload strategies of the Advanced Transporter	63-64
11.6. The use of several Transporters	64-66

2 Tutorial Layout

2.1 The learning perspective

This tutorial teaches beginners to find their way through the Enterprise Dynamics (ED) simulation package.

The tutorial starts in Chapter 4 with Enterprise Dynamics's opening window. From there and through a progressive approach, you will get to know increasingly more about Enterprise Dynamics. This occurs mostly through examples: small problems in a specific context. You will learn about the functionality of Enterprise Dynamics by building and experimenting with models.

This approach has several advantages:

1. The user learns Enterprise Dynamics through modeling a simulation problem, which corresponds to the purpose for which the package is being used in practice.
2. The functionalities of a program are more effectively learned when they are connected to applications.
3. The user can refer back to several solutions in examples when he or she is confronted with a similar problem.

Briefly, this tutorial aims not only to show *what* a function of the software does, but also *how* and *when* it can be applied. In addition, some parts of this tutorial can be used as a reference function, for example the overviews in the annexes.

To be clear, this tutorial does not make the manual - available under the help menu (or when you press F1) - superfluous. Users who wish to reach a higher level in building simulation models will use the manual frequently, as it forms a complete documentation for all software functionalities.

2.2 Notation

When a submenu is referred to, the symbol | is used. So, File | Preferences refers to the submenu Preferences (consisting of a number of standard functions), which can be found under the File menu. Emphasis on important matters is rendered by **bold** or *italic* writing of words. The case studies and the related questions are written in this font. When 4DScript code is to be found in a text, *this font has been used*.

A warning is preceded by: *Warning!* and an important tip, are displayed in a Tip box:

 Important tips are displayed in Tip boxes.

2.3 Tutorial Structure

Chapter 3 gives a short general introduction about the Enterprise Dynamics program. Chapter 4 explains Enterprise Dynamics's menu and window structure.

The basic principles of the package are being demonstrated in chapter 5 by a simple queuing problem with just one server. Later, two servers are added in order to show the concept of "channels". The atoms used in this instance are Source, Queue, Server and Sink.

Chapter 6 shows different methods to observe the results of a study. We use an example of a carpenter's factory, to explain the batching of products in Enterprise Dynamics. The user learns to use the: Monitor, the Summary Report, the new Experiment Wizard and displaying various graphics. Furthermore, the steps to go through in a simulation study are practiced at a beginner's level: model building, validation, experiment layout and analysis of results.

In Chapter 7, the emphasis is placed on observing the pre-programmed methods through which products get access to a next atom (input strategy), are placed in a queue (queue discipline), or are redirected after use (send to).

Chapter 8 introduces eight new atoms including the Assembler and the Conveyor atom, while Chapter 9 is dedicated to the link between Enterprise Dynamics and Excel. This chapter also provides a start in 4DScript and an introduction into labels.

Chapters 9 is dedicated to the Human Resource atoms and Chapter 10 to Transporters.

Besides this tutorial another important the tutorial is available: 'A first start in 4DScript'. This tutorial forms the Enterprise Dynamics Tutorial

starting point for learning the underlying programming language in Enterprise Dynamics.

2.4 Learning Simulation

Simulation is not a simple technique. The sensible use of a simulation program requires knowledge about the theoretical background of discrete simulation such as probability distributions, the model building process including validation techniques and the design of experiments. Although the tutorial gives insights in this field, it is not a textbook regarding simulation in itself. For this, one can refer to existing books or lecture notes about discrete simulation.

Developing a feeling for simulation and model building in particular are for the better part a matter of lots of practice.

Examples of the models in this tutorial are also included in Enterprise Dynamics. Use them when in doubt whether your own models are correct.

3 Enterprise Dynamics's Background

Enterprise Dynamics is an object-oriented software program for modeling, simulation, visualization, and control of dynamic processes. The users can pick up objects - called atoms - from standard libraries in order to build their own model. Enterprise Dynamics is based on this concept of atoms as modeling objects in each model.

An atom can represent a machine, a counter or a product but it can also have a non-physical character like a graph. As far as the difference in the type of atoms is concerned, we will mention *basic atoms* (five atoms often used: product, source, sink, server and queue), *transport atoms* (relating to transport such as conveyors or transporters), *results atoms*, etc.

Thanks to the open structure of Enterprise Dynamics, the advanced user can build new atoms, for example to model a machine with very specific characteristics. At the moment, Enterprise Dynamics includes 100 standard atoms, but this number is ever increasing. The beginner may typically only need to select from around 30 frequently used atoms to have enough material for his or her applications.

Atoms are predefined modeling objects used to build models quickly and to carry out studies. Enterprise Dynamics also has a built-in programming language called 4DScript, which can be used for setting specific conditions from reality in the model. In this tutorial we will address 4DScript only briefly.

Thanks to the open structure of Enterprise Dynamics, the user can create its own library that should be loaded when Enterprise Dynamics is started using the packages structure of Enterprise Dynamics. It is also possible to create a new menu structure and layout.

Enterprise Dynamics allows a problem solver to model virtually any problem and, by experimentation, look for a solution for a given problem or an answer to a specific question. Advantages of using Enterprise Dynamics within industry and logistics are:

- The ability to test a future system in an early design stage.
- Testing and improving proposed modifications resulting from e.g. Lean Manufacturing or Six Sigma studies, without impacting the operational environment.
- Modeling and analysis of several scenarios, such as Rough-Cut Capacity Planning, to be prepared for the future.
- Optimization and safeguarding of investment planning for production and transport equipment.
- Estimating the influence of uncertainties and variations, like failures and variable process times on system performances.
- Analysis and visualization of operational systems in 2D and 3D animation.

Enterprise Dynamics Educational is our offering for educational purposes, consisting of a combination of the Enterprise Dynamics software with a number of elaborated case studies which the teacher can use for student assignments.

This tutorial can be used to learn the basic skills necessary to work with Enterprise Dynamics. Furthermore it addresses topics and questions that typically arise in simulation studies and is therefore an important part of Enterprise Dynamics Educational.

InControl Simulations Solutions is a simulation solution provider: in addition to building, developing and selling the Enterprise Dynamics software, it also provides extensive services in the field of computer simulation, such as training and consulting. The consulting services involve carrying out simulation studies as well as application building.

4 Getting Familiar with Enterprise Dynamics

4.1 Starting Enterprise Dynamics

Enterprise Dynamics can be started from the Windows Start Menu. During the startup a splash screen appears, see Picture 4-1.



Picture 4-1: Splash screen

When you start Enterprise Dynamics for the first time you are presented with the Example Wizard. The wizard offers a selection of the available example models that come with Enterprise Dynamics. Switch to the Examples page to view all the available models, see Picture 4-2. Later, you can also open the Wizard from the Help menu. Just click on one of the models to open the example.

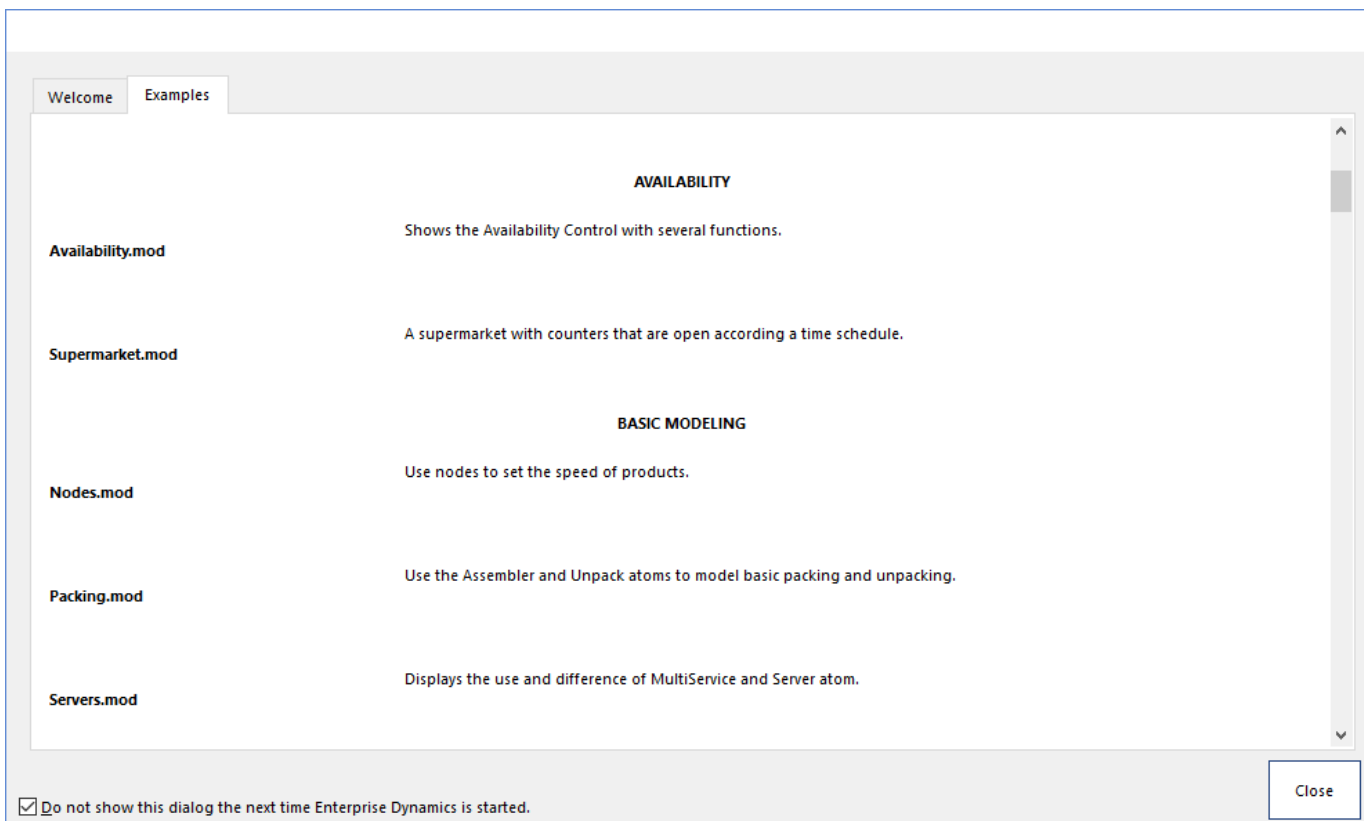

Picture 4-2: Example page of the Example Wizard

4.2 The window sections

As soon as Enterprise Dynamics is started up completely, the opening window should be approximately like Picture 4-3.

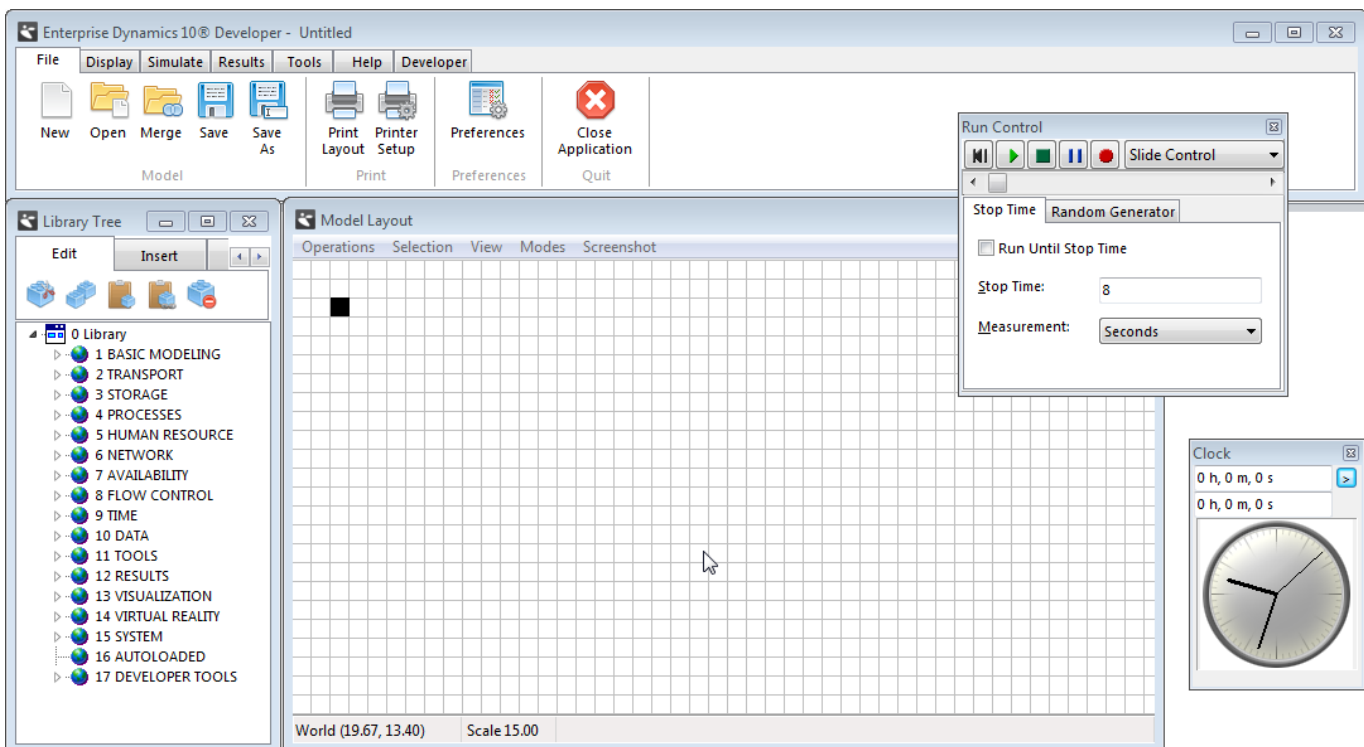

Picture 4-3: Layout of the opening window in Enterprise Dynamics

The window is divided into the following sections:

- A *menu bar*: among others for opening and saving files. Section 4.3 covers the menu structure more thoroughly.
- The *library*: The library includes all atoms a user can place into a model. Each atom has a certain function. By combining the right atoms, it is possible to re-create ('model') a business process in Enterprise Dynamics. Model building is described in chapter 5.
- The *model layout window*: this is where the model is being built.
- The *run control*: use this to reset and start the model and to regulate its execution speed.
- The *clock* displays the simulated time already elapsed during the simulation (not the real time!).

4.3 The menu structure

The function and the appearance of the menus are like those in other Windows applications, such as Word and Excel. The most used menu options are explained in the table below.

The main menu is to be found in the menu bar, which is subdivided as follows:

File	Make, open or save files, to set preferences and to control standard functions such as printing.
Display	Open viewer and layout windows to display models and to open the library windows with modeling objects.
Simulate	Open a Run Control or Clock window. Design and perform an experiment.
Results	To generate reports and graphics of a <i>single</i> simulation run or evaluate results of an experiment.
Tools	Contains tools such as the 4DScript interact and Autofit to fit a distribution to given data.
Help	Open the documentation, the Example Wizard as well as to find company and version information.
Developer	Tools useful for developer to create libraries and attribute functions.

Each main menu item is divided into groups. See the documentation for a complete description.

4.4 Structure of the library and the model

Enterprise Dynamics uses a tree structure to visualize the organization of atoms. With this structure the user can easily see which atoms contain which other atoms. The main tree gives a complete overview of the application, the library and the opened model.

Two important trees are:

- The Library Tree (see Picture 4-4) which lists all atoms a user can insert into the model. The atoms are divided into groups, for example a *transport* group and a *human resource* group. By selecting an atom and dragging it into the model window (the 'Model Layout' or '2D Builder'), the atom is added to the model.
- The Model Tree, where all the atoms used in the current model are listed. Press F5 to refresh the list.

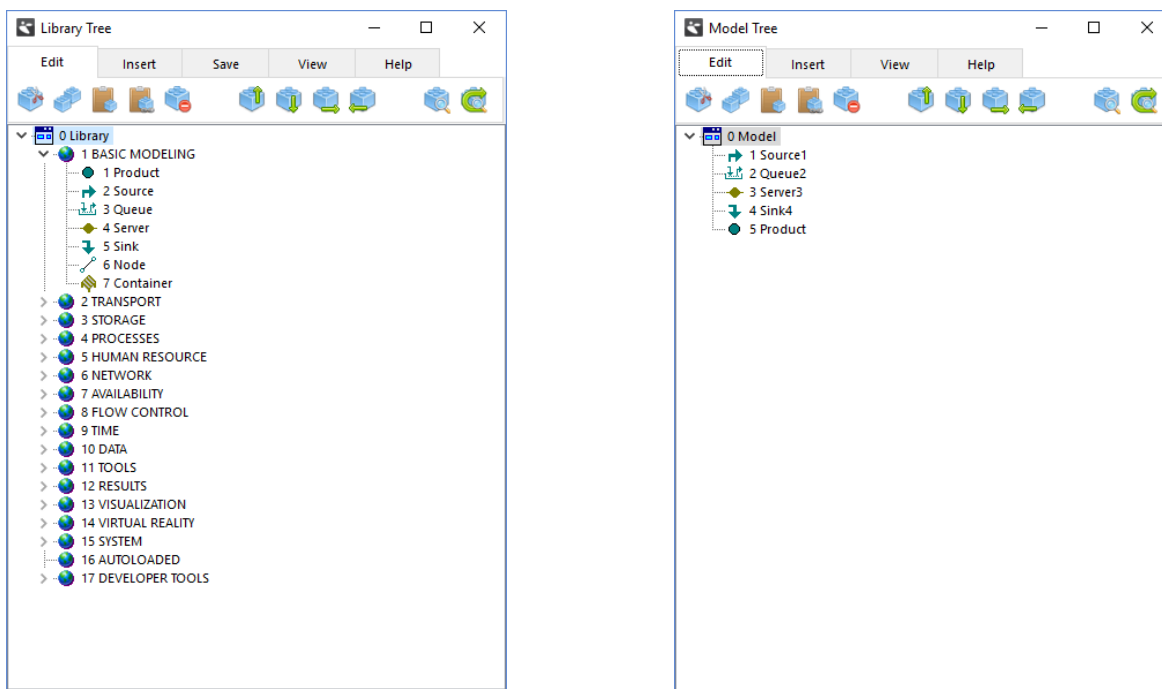

Picture 4-4: The Library Tree & Model Tree of Example 1

The 2D Builder or Layout window and the Library Tree can be opened from the Display section of the main menu. The shortcuts are shown in Picture 4-5.



Picture 4-5: Buttons to open the Library Tree and 2D Builder window.

5 Model Building Basics

In the previous chapter, the theoretical aspects of Enterprise Dynamics have been discussed. In this chapter, we will start by building a simple model in Enterprise Dynamics. The objective here is to learn about Enterprise Dynamics, not to fully complete a simulation study. At the end of this chapter, the user should be able to develop a model in which several machines are used simultaneously.

5.1 Dragging atoms into the model

The first step in the creation of a model is selecting the required atoms and placing these into the model. In this section, we will start by building a simple model that consists of the following four parts, see Picture 5-1:

Source: The function of this atom is generating products into the model.

Queue: This atom is a waiting area for customers or products.

Server: The function of this atom is that of a machine or of a counter. Atoms entering a server undergo a process and remain in this atom for a certain time (the process time).

Sink: The products or customers leave the model through this atom.

Example 1

An average of 20 customers per hour come into a post office. The assistant has on average two minutes to help a customer. Of course, the number of customers may vary from one hour to another.

The two-minute time that the assistant has to help a customer can vary as well. A customer who only wants to buy stamps will need less time than a customer who wants to open a new account. The customers are served on a first-in first-out basis.

A few customers complained about the queues and because the post office manager is very concerned about the service to his customers, he wants to inquire into this problem.

Questions and assignments

1. How high is the utilization of the post office assistant? What does that mean?
2. Can you make an estimate of the average queue length?
3. Which characteristics would you measure for the post office manager?

Simulation is a tool to gain insight into the average queue length. Because this model is the first one we are going to build, it will be dealt with step by step.

We therefore use the four atoms mentioned in the beginning of this section and put them into the model in the above-mentioned order. The first one is thus the **Source**, then the **Queue**, the **Server** and finally the **Sink**.

These atoms and many others can be found in the Library. Just select an atom and drag it onto the Model Layout window. The four atoms that are required for this model can all be found in the first category “BASIC MODELING”. Click the “+” belonging to the first category “BASIC MODELING” to open the section, then drag a **Source**, then the **Queue**, the **Server** and finally the **Sink** in the model. When this is done, you get to see Picture 5-1 on your screen:

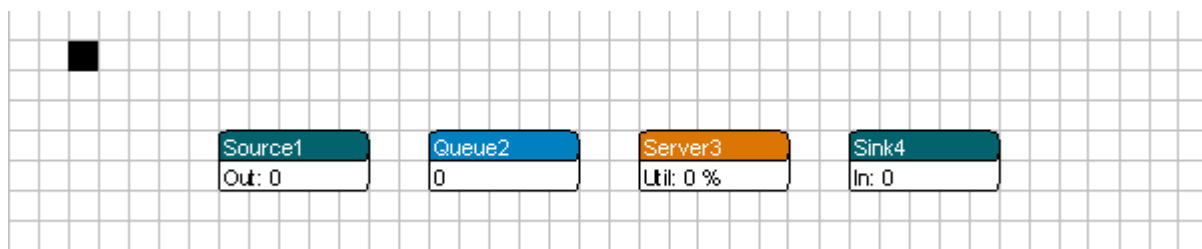

Picture 5-1: The first model

In case of errors, click on the atom concerned and press ‘delete’ to remove the atom from the model.

To check whether the customers walk through the model in the correct sequence, we will start a simulation run using the Run Control window. If this window is not visible yet, switch to the Simulate page in the main menu and press on the Run Control button. In the Run Control window, the sub-function Slide Control has to be selected,

see Picture 5-2. This function enables you to adjust the speed of the simulation.

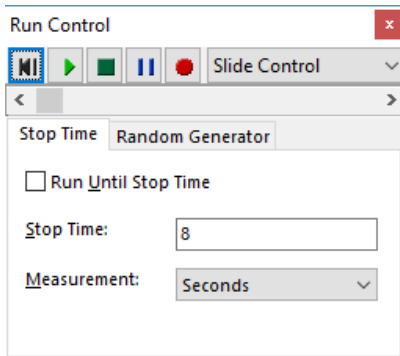

Picture 5-2: Select Slide Control

Before the simulation can start, you first have to click on the Reset button. It is the leftmost button in the Run Control window. After clicking on the Reset button, a blue dot appears next to the Source atom. This is a product atom. By clicking on the start button (green triangle) the products, in this case customers will pass through the other atoms, in this case the post office. If necessary, adjust the speed by dragging the speed button in the Run Control window!

By right-clicking anywhere in the Run Control window a context menu will pop up with the following options:

- Stay On Top. If this option is checked, the Run Control window will always be on top of other windows, including windows of other applications.
- Show Settings. With this option you can hide and show the settings tabs in the Run Control window.

In this model no queue will form before the counter (Server). As a result, the blue dot is only visible in the counter (Server). The percentage displayed in the Server reflects the utilization of the Server so far. When the percentage is not visible, you might need to zoom in or zoom out. Click on the left and right mouse buttons simultaneously and move the mouse forwards and backwards to zoom in or out.

The atoms have been placed in the right order, but we still need to enter how many customers per hour are coming in and how long the assistant needs to help a customer. Before you enter these cycle times in Enterprise Dynamics, you have to know that *all cycle times in Enterprise Dynamics are defined in seconds*. When the post office assistant needs two minutes to help a customer, you enter 120 seconds in Enterprise Dynamics. Equally, we must define how much time elapses between customer arrivals, called the Inter-arrival time, in seconds.

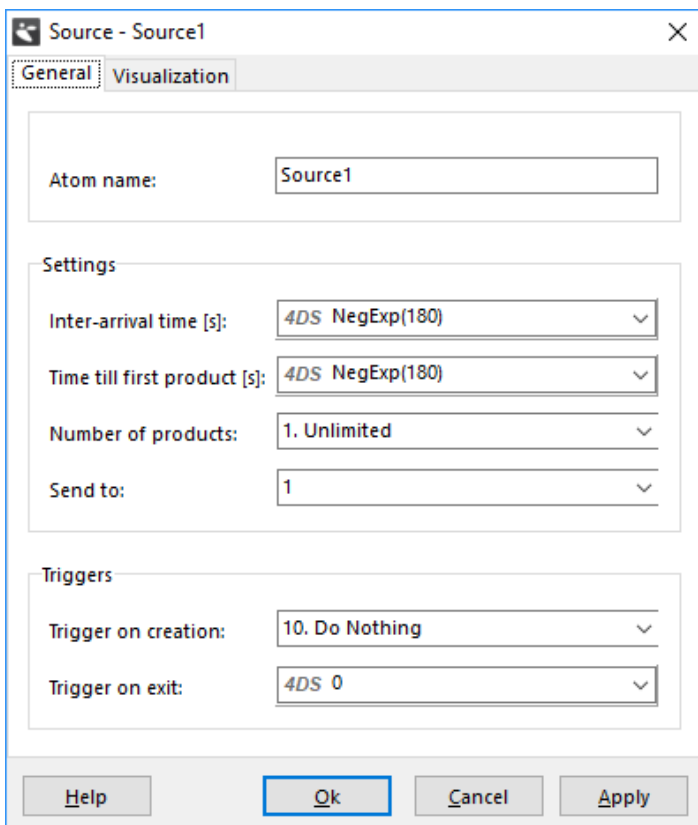

Picture 5-3: Input window Source

First, we change the parameters of the Source, so that an average of 20 new customers per hour arrive at the post office. Right-click (or double-click) the Source atom, an input window appears, see Picture 5-3. On the “General” tab the most important parameters of the Source can be found. The time elapsing between two arrivals can be entered in the *Inter-arrival time* field. We use a probability distribution to model the uncertainty in the arrival process. In this example, the negative exponential distribution is used, which is a probability distribution often applied in unpredictable arrival or service processes. In Enterprise Dynamics, the following 4DScript code has to be entered: `NegExp(e1)`, where the parameter `e1` stands for the average value or expectation of the exponential distribution. Now enter 180 as inter-arrival time and confirm with OK.

Important: To the right of the input fields, you will often find a triangle pointing downwards. Clicking or double clicking on this triangle opens a list with available and pre-defined options. First check whether any of these options might be useful for your specific case! For an explanation of these options see the Enterprise Dynamics Help file. The Help contains a full description of the most important atoms and their input fields. The grey letters ‘4DS’ indicate that 4DScript commands, Enterprise Dynamics’s programming language, can be entered.

The time that an assistant needs to help one customer has to be entered as well. Again, the negative exponential distribution is used. Now, right-click or double-click the Server atom, so that the service time can be adjusted on the “General” tab sheet, see Picture 5-4. Select “`NegExp(10)`”. A 4DScript window will appear. Adjust the cycle time in such a way that the assistant needs an average of two minutes to help one customer.

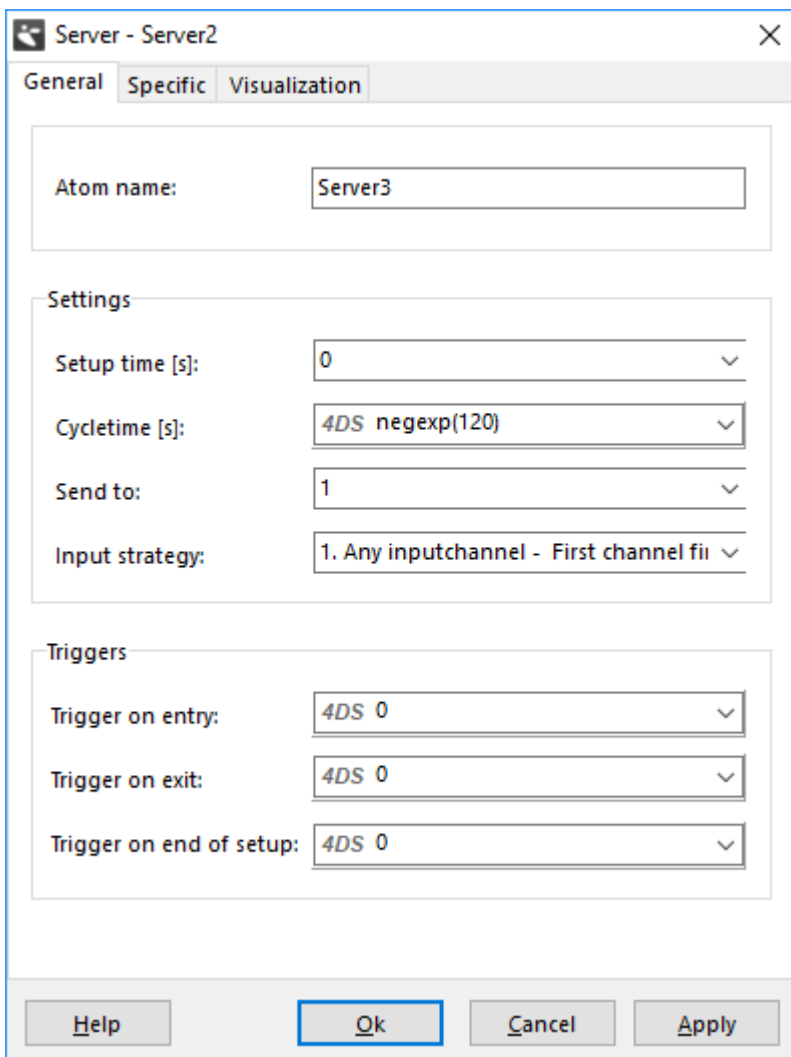

Picture 5-4: Input window Server

Reset and restart the simulation with the Run Control. Because we have increased the time between two arrivals, it is a good idea to increase the simulation speed. By zooming in sufficiently, you can see how many customers are waiting in the queue.

You can replace the blue dot, representing a customer in our example, with another icon. To do so, double-click the blue dot to the left of the source. Double-click on the edit field of the "2D Icon" that can be found on the "Visualization" tab. The Resource Manager will appear, featuring (some of) the icons the users can select. Click on the icon you want to use and select OK: the blue dot in the Product input window is replaced by your new icon. Confirm this change with OK.

The icon that Enterprise Dynamics uses in the 3D display can be changed as well. Use for this the option 3D Icon and select the Person icon from the list. Now display the model in 2D and 3D. To open the 3D visualization: select the Display page of the main menu and click on the 3D Viewer or 3D Builder button. To navigate through the 3D model, move the mouse and click on the mouse buttons.

 There are many more icons available with the Enterprise Dynamics installation. You can also add your own icon files to the Resource Manager and use these in your model. Click on the Resource Manager button on the Tools page of the main menu to open this window. Click on Add, a window appears. Browse and select an icon and click OK to add it to the Resource Manager. You then can use this icon as the 2D icon of a product.

In this case, the icon is only changed to improve the visualization. However, if distinguishing between different types of customers is necessary, the use of several icons can bring additional clarity. For example, one group of customers could be represented by a green icon and another by a blue icon.

The model can now be saved, with File|Save as. For reference purposes, the model of this post office can be found in the folder tutorial models under the name Postoffice1.mod.

5.2 The Channels

Example 1 (continued)

In the neighborhood, two post offices have been shut down. The manager hopes that many new customers are going to use his post office and even expects twice as many customers in the near future. As a result, an average of 40 customers will come into his post office per hour. In order to figure out if his post office can manage this flow with the existing counter, he decides to carry out a new simulation study.

Questions and assignments

- Does it make any sense to simulate this situation? In order to answer this question, use the expected utilization and check your own supposition by modifying the model `postoffice1.mod` to the new situation and by carrying out a simulation run.

Example 1 (continued)

It seems that one counter will not be enough to manage the flow. The manager now wants to open 3 counters to be on the safe side. Once again, he wishes to see the effects of this adjustment on the queue.

To begin with, we put the two counters under the existing counter (select the right atom to model a counter). Then, the parameters for the counters' cycle times have to be changed in such a way that they correspond to the first counter. To this end, you might want to go back to chapter 5.1. The model should now look like Picture 5-5.

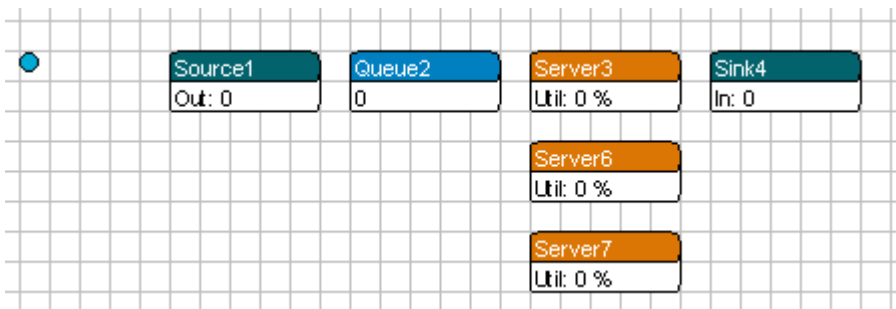

Picture 5-5: Post office with three counters

 Atoms can simply be copied -including all entered fields and parameters-! For this, first click on the atom to be copied and then on F6: a duplicate of your atom is created. You can also use Ctrl+C to copy and Ctrl+V to paste the atom.

To copy more than one atom right-click and select an area around these atoms or hold down the Ctrl-key and click on the atoms to add these to your selection: click F6 or use Ctrl+C to copy the selection and Ctrl-V to paste it. You can reposition the entire selection at once.

When the simulation is started, you will see that the customers are still sent to the first counter. In order to correct this, we have to look into the method that Enterprise Dynamics uses to direct the customers.

In the View menu of the Model Layout window, select the option Channels, see Picture 5-6. By doing so, the channels of the atoms appear. The purpose of these channels in Enterprise Dynamics is to route products and to transmit information.

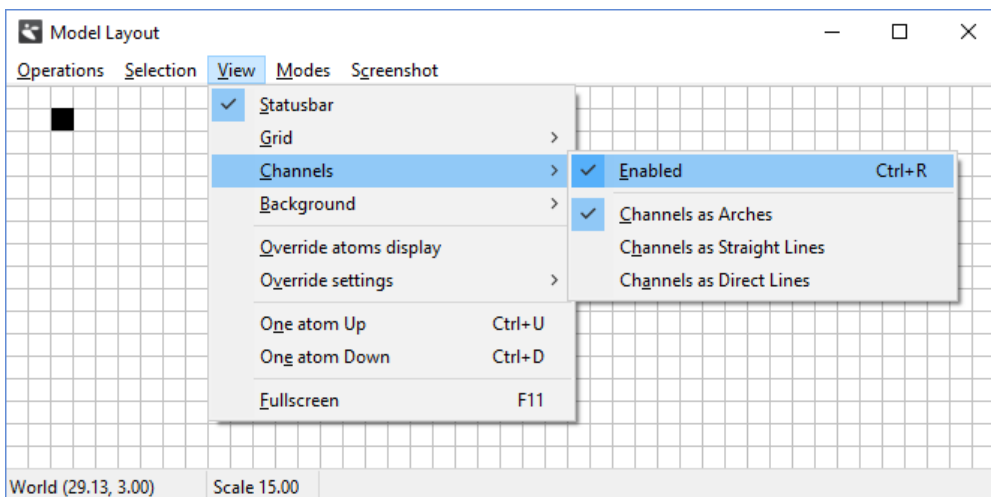

Picture 5-6: Switching on Channels

Switch on the option enabled to see the channels, see the result in Picture 5-7.

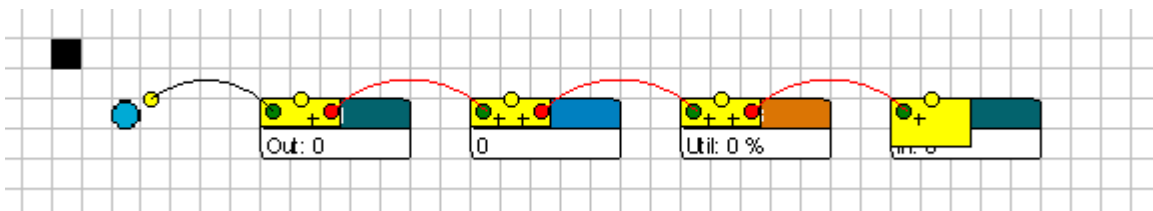

Picture 5-7: The original model of the post office with channels switched on

When the lines between two channels do not appear curved but squared, it might be helpful to switch on the option Channels as Arches in the View | Channels, see again Picture 5-6. As soon as the channels are switched on, a yellow box is shown in the upper left corner of all atoms. This box contains the input and output channels of the concerned atom, see Picture 5-8.

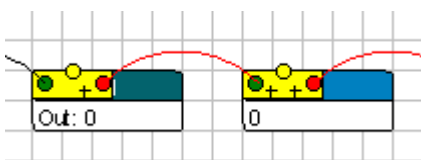

Picture 5-8: Connected channels

The box contains several dots, the left dot is an input channel and the right one an output channel. A channel can be *open* (in green) or *closed* (in red). When both the input and output channels are open, the connection between the input and output channels is *ready* (in green), otherwise, the connection is *not ready* (in red).

Products come into an atom through an input channel and leave the atom through an output channel. An input channel has to be connected to an output, whereas an output channel has to be connected to an input. Each input or output channel can only be connected to one other channel.

By clicking on the “+” sign next to a dot, the number of input or output channels can be increased. By right clicking a channel dot, an overview of all connections of the atom appears. The “-” sign (which appears as soon as the number of input and output channels is two or more) speaks for itself.

The yellow dot in the middle of the channel box is designed to receive (but not send!) information, this channel is called the Central Channel. The central channel cannot be used to send product atoms to other atoms but used to register information regarding an atom. Later we will see that the input channel of a result atom can be connected to the central channel. Both input channel and output channels can be connected to central channels. There is always only one central channel present on an atom, but *several atoms can be connected to the same central channel*.

Important: Although you can use channels for many purposes, the basic function of channels is the indication on an atom (read: queue, counter) of all possible next locations for products in this atom. In this way, the channels provide a (rough) routing of products through the model!

Picture 5-9 represents an atom with 4 input channels, 6 output channels and the central channel.

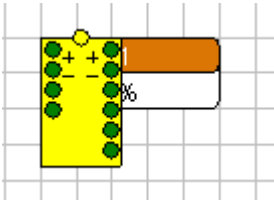

Picture 5-9: Atom with 4 input channels and 6 output channels

💡 One of the revisers of this document happens to be color-blind, (as are most laser printers) and therefore has trouble distinguishing an open (green) and closed (red) channel. You can change these color settings in Enterprise Dynamics yourself by clicking File|Preferences ...|Appearances. Change the color of “2D -> Open channel” and “2D -> Closed channel”.

By dragging a line between an output and an input channel with the mouse cursor, two atoms are connected with each other. By dragging a line between an input or an output channel and the central channel of the same atom, a connection is broken.

Now connect the channels in the Enterprise Dynamics model in such a way that the customers only go to one of the three counters and afterwards from one counter to the exit. The result should look like Picture 5-10. Restart the simulation (do not forget to reset!) and check if the customers now go to the right counters.

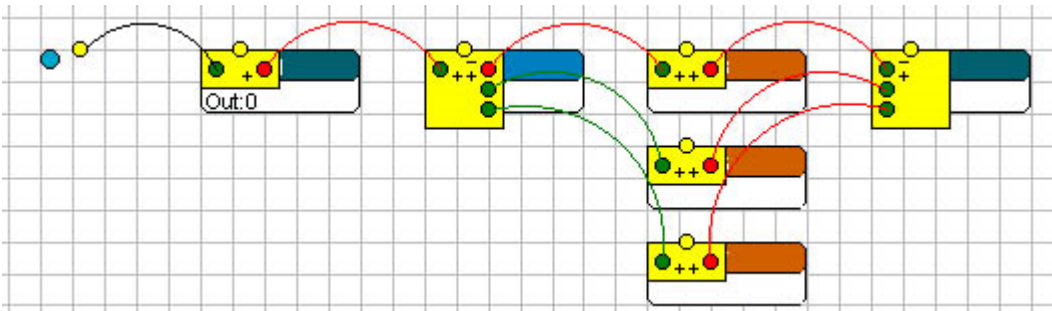

Picture 5-10: Post office with connected channels

The reason why the customers are still only going to the first counter is that unless we tell Enterprise Dynamics otherwise, it sends all products through output channel 1. In the input window that appears by double clicking or right clicking an atom, you can specify the channel through which the products should leave the atom. By double clicking on the Queue, we can alter the parameters of our model. In this case, we have to adjust the value in the Send to field, see Picture 5-11: if we want that each open channel can be selected, the predefined options 2, 3 and 4 are relevant.

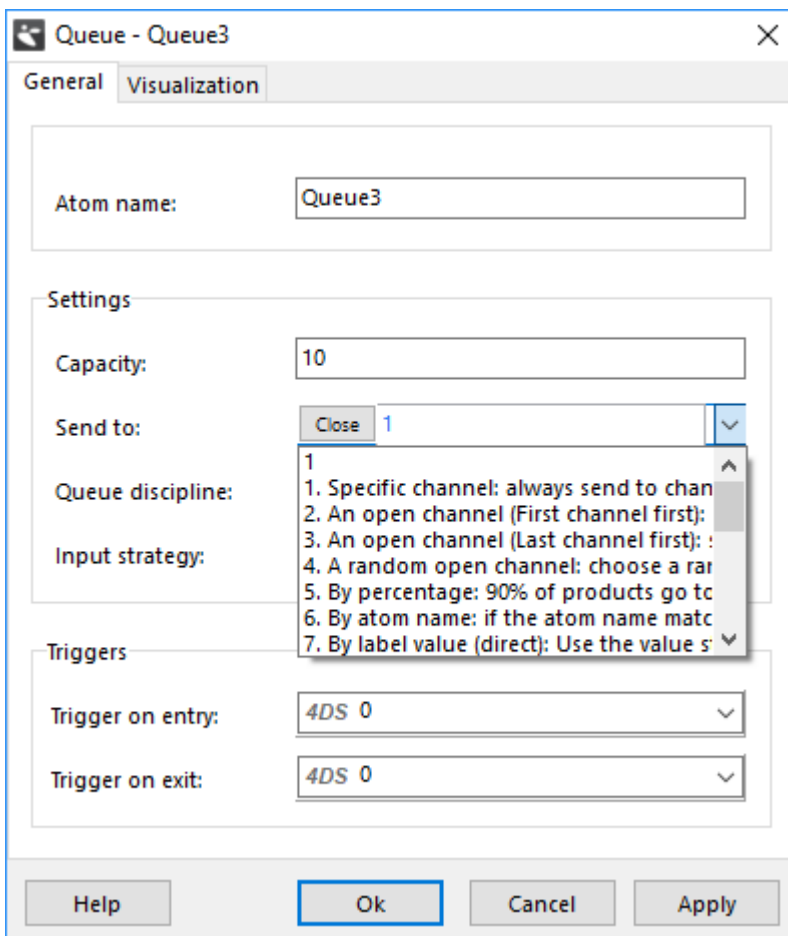

Picture 5-11: The list of predefined option for the "Send to" property of the Queue

Explain why in option 2 or option 3, either the first or last server will get the highest utilization, while the servers' utilizations in option 4 will be more or less the same after the simulation has run for some time!

In the Send to field, you can either enter a number, write a short piece of 4DScript code that will result in the output channel number, or use predefined code. For beginners, the last option is definitely the easiest method. By clicking on the small down triangle in the input field, a list appears, showing the predefined options that the user can select. After a certain option is selected, text displayed in blue can be modified. Obviously, this possibility is only applicable if there is something left to change.

Now select a strategy in which the utilization of the 3 counters is about the same. If the utilizations of the counters are not directly visible, use both mouse buttons in order to zoom in or zoom out. View the model also in 3D with Display | 3D Viewer or Display | 3D Builder!

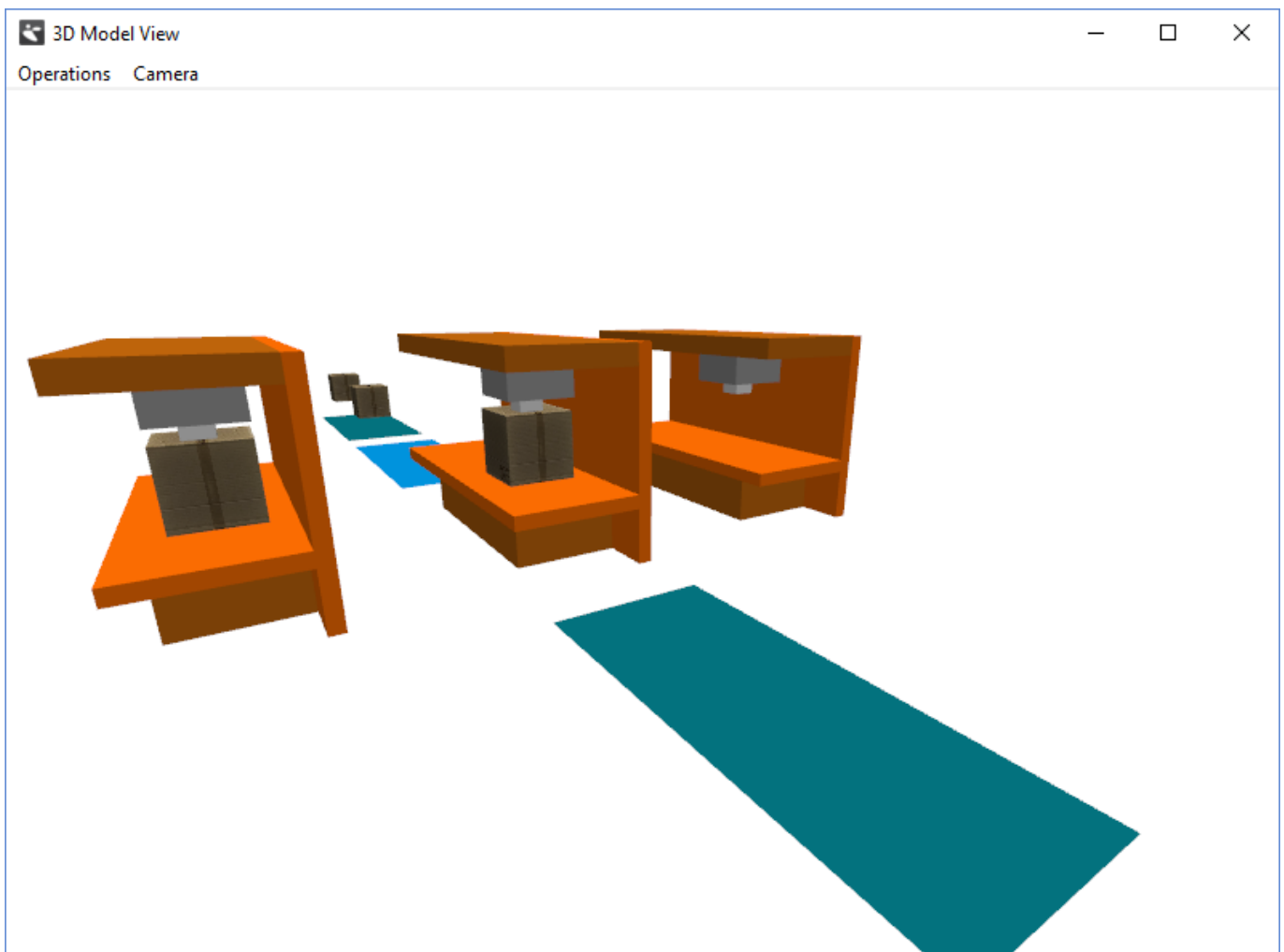

Picture 5-12: The 3D-model with the three counters modeled as machines

Questions and assignments

5. Is the layout with 3 counters sufficient?

The model can be saved now. For reference purposes, the model of this post office is to be found in the folder tutorial models under the name Postoffice2.mod.

6 Analyzing the Results

In the last chapter we used a detailed and progressive method to simulate a post office. You learned how to place atoms in a model, and how to connect the channels between atoms. You also learned how to create a flow of product atoms into the model at a defined interval, and how to make them stay on a machine (counter) for the correct processing time. As a result, all the basic principles for building a model have been dealt with.

In this chapter, we are going to build a more complex model and above all observe how to follow and measure the results of a simulation study. We will once again start with a (simple) example and (after building the model) explain the different ways of measuring results. Next, we will practice this in the model.

Example 2: The carpenter's factory

General context:

A carpenter's factory often has its own design department. This department is complex to manage because each order consists of a separate project, in which the process times of each production step has to be estimated as accurately as possible. Large intermediate stocks, long throughput times, and variable bottlenecks often characterize such an environment.

The management of a carpenter's factory, which mainly produces windows and window frames, wishes to gain insight into bottlenecks, production numbers and throughput times. For this purpose, they decide to have a simulation study carried out. To keep it simple, in this case only the production of windows is included.

The window production process can be divided into several steps. First, long timbers come in, which are cut into 10 shorter lengths on a saw. Next, these shorter pieces are cut into the desired pattern on two milling machines. When the parts have been milled, they go to the bench vice.

At this stage, four pieces at a time are placed in a frame and glued. There are two milling machines and two bench vices, operating in parallel, so the parts pass through milling and gluing only once. There are storage areas between all consecutive production steps, and there is a continuous supply of raw material. To control the stock levels, each intermediate storage space is limited to 100 parts.

The time to saw the incoming timber into shorter lengths is uniformly distributed between two and three minutes and the processing time on the milling machine is normally distributed with an average of 36 seconds and a standard deviation of 2 seconds.

The bench vice takes exactly two minutes to glue a window together. The production process takes place continuously between 09:00 to 17:00 hours. The products that are not completed at the end of the day remain until the next day.

Questions and assignments: Analysis beforehand

1. Make a drawing of the process with the capacity per hour in raw lengths, milled lengths and frames for each production stage.
2. How many window frames are expected to leave the factory each day?

Now build the model in Enterprise Dynamics. The probability distributions can be found in the drop down menu of the cycle time. Note that for the normal distribution, the formula `max(0, normal(36,2))` is used to prevent negative service times. Change the Batch rule on the "Specific" tab of the Servers; use the Batch Rule "1 in, B out" with batch size 10 on the servers for the 1:10 operation from timbers to short lengths and the batch rule "B in, 1 out" with batch size 4 for the 4:1 operation from short lengths to frames. Change the name of the Servers, so that the model is easier to read. If everything went well, your model should look like the model in Picture 6-1.

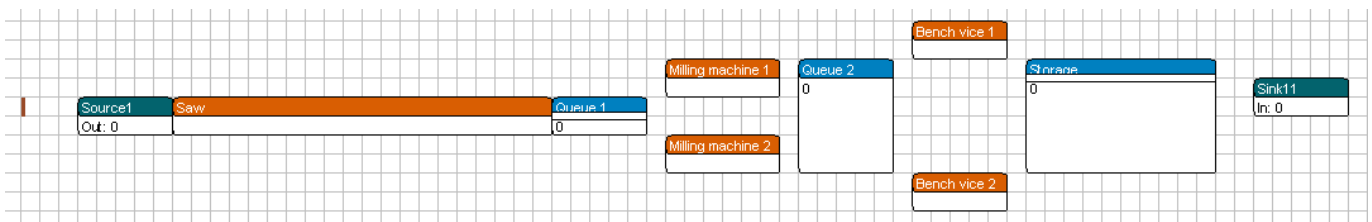

Picture 6-1: Layout of the carpenter's factory

Changing the size of the atoms can be done by clicking the atom, and then dragging its upper left or the lower right corner.

The Product atom (the blue dot) can be changed into a brown 'timber': double-click or right-click on the product

and change the input field as indicated below.

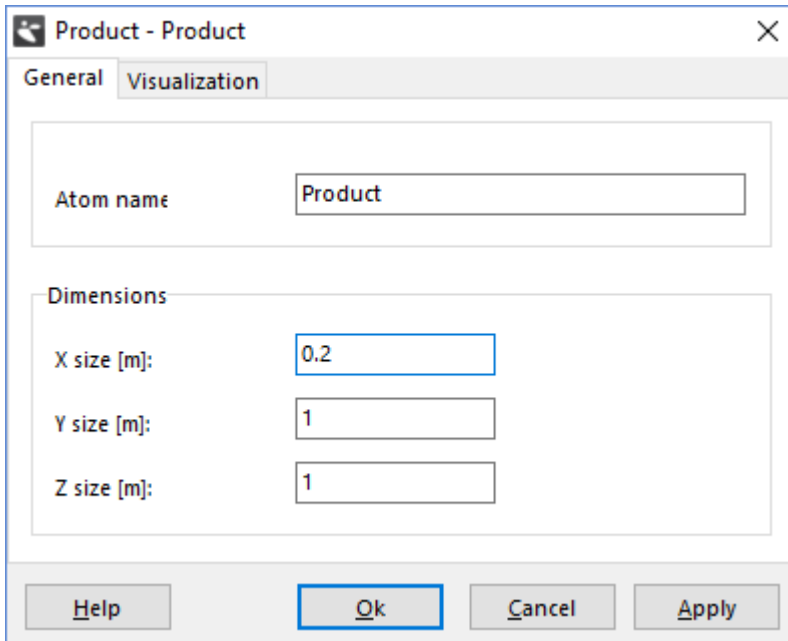

Picture 6-2: Changing the product's general settings

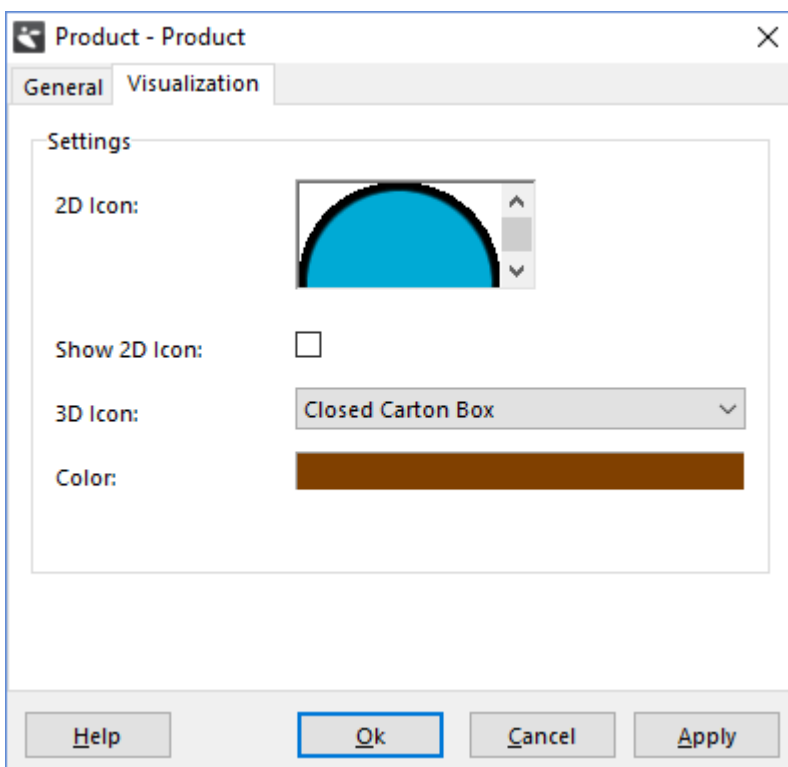

Picture 6-3: Changing the product's display

Save the changes you have made. Which changes did you make?

The 2D icon with the blue dot is still there, but if 'Show 2D icon' is unselected only the brown background remains visible. The product has a length of 0.2 meters and a width of 1 meter, similar to a timber in upright position. In 3D, the height (size z) of 0.2 meters plays a role. Note that the product icons can differ in 2D and 3D. In 3D, select e.g. the pallet or another icon!

In 2D, the grid visible behind the atoms functions as a grid for coordinates. Each square represents an area with a size of 1 x 1 meters. The black square marks the coordinates (0,0). Physical dimensions do not play a role in this abstract model of a carpenter's factory, but they definitely do play a role in other applications such as warehouses with short walking distances, or fork lifts having to cover a certain distance!

If you are not sure that you got your own model correct, you can also use the supplied model timber1.mod in the next sections.

6.1 Techniques to measuring the results

Now that we have a working model, we can start with the measuring results. Within Enterprise Dynamics, there are several techniques that can be used:

1. Information indicated on the atoms.
Each Queue shows how many products are in the queue, each Server shows its utilization and each Source or Sink shows how many products have entered or left the model. This information is particularly useful to see if a model is working logically during the simulation (which is part of the verification of the model).
2. The Result Atoms.
The Results atoms can be found in the Results section of the library. For example, the StatusIndicator and StatusMonitor atoms display the current status of an atom and the fraction of time that the atom is Busy, Idle or Blocked.
The Generic Monitor Atom can graphically display other information about an atom. The user can select which information is to be shown, and in which form. This atom is particularly useful to validate the model.
3. The Summary Reports and the Graphs from the Results menu.
The intermediate results of a simulation run are shown here. This method is especially convenient for a quick overview of the system's status and a rapid feedback of the effect of changing various parameters.
4. Setting up an experiment with the Experiment Wizard.
This technique is quite different from the last three and is used for the actual study. The length of a measurement period and how often this period is to be simulated, e.g. 10 times half a year, is set beforehand. We must also specify what variables we want to measure. At the end of the experiment the mean values of the variables are given within confidence limits.

6.2 Measuring the results

In section 6.1, four techniques have been presented, through which the results of a simulation study can be shown. In this section, we are going to apply these four methods to the carpenter's factory. For this, the carpenter's factory model has to be opened in Enterprise Dynamics.

1. Information shown on the atom

The clock function in Enterprise Dynamics has to be visible on the screen (submenu of Simulate). Start the simulation and see how many products leave the factory within eight hours. In the Run Control window check the option "Run until stop time". Set the stop time on 8 and measurement on hours. If you now start the simulation, it will stop after exactly 8 hours.

Questions and assignments

3. Perform this a few times and note the number of windows produced. Does this correspond to the analysis carried out previously? What is the bottleneck in this process?

2. Results atoms

The use of the results atoms is quite simple. The Library Tree (and not the Model Tree) has to be opened. Look for the StatusMonitor atom and the GenericMonitor atom in the Results group and drag them into the model. Note that the StatusMonitor can be found in the group Status within the Results group.

To use the StatusMonitor, it is sufficient to connect its input channel to the central channel of the atom to be monitored. When the simulation is reset and started, the StatusMonitor atom will automatically begin displaying the status statistics. In this case connect it to one of the bench vices, reset the model and press Start. Examine which proportion of its time the bench vice spends on waiting for timber to arrive, on collecting timber after the first arrived, and on actually processing the timber. If the channels are switched on, the atom should look like Picture 6-4.

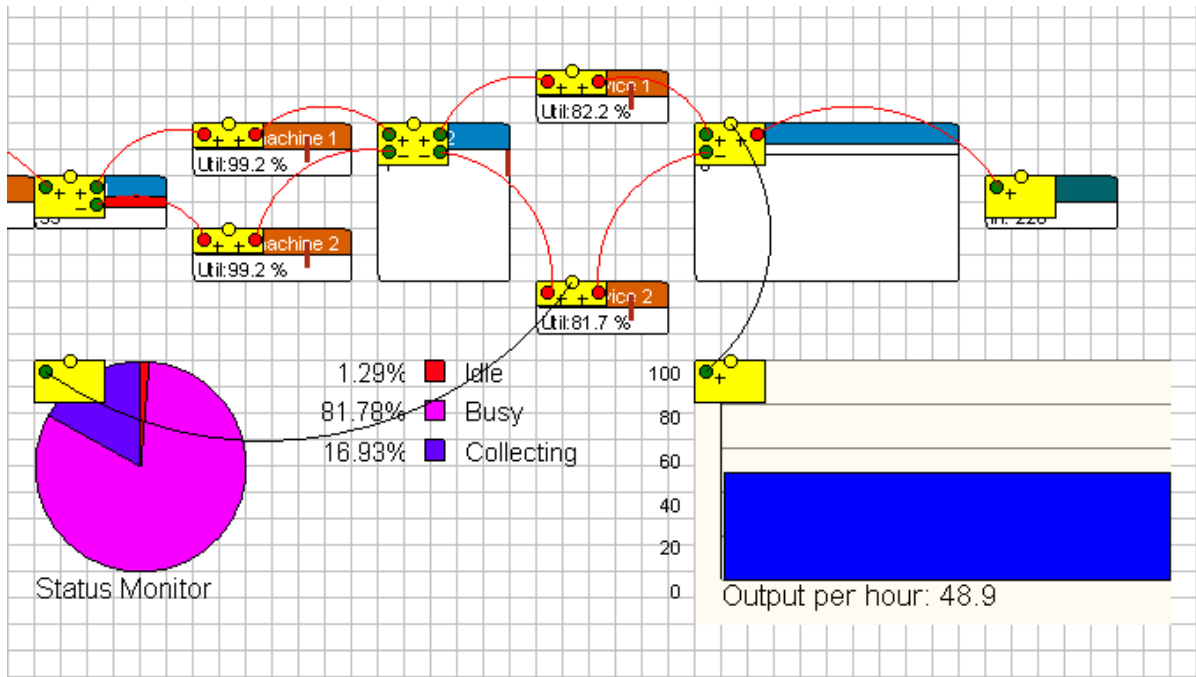

Picture 6-4: Part of the model with (already connected) Result atoms; left a StatusMonitor on the right a GenericMonitor.

Configuring the GenericMonitor atom takes more work. Again, the first step is to connect the monitor with the atom you want to observe. In this case, we want to know how many windows are leaving the factory per hour. As a result, the monitor has to be connected with the Queue before the Sink. Connect the input channel of the monitor to the central channel (the information channel) of the Queue. You can also double-click or right-click the monitor atom and then press the button “Select Atom” select from the list that appears the atom that is going to be observed.

Secondly, you have to enter what is going to be observed. For this, double-click or right-click once again on the monitor atom and adjust the “Variable to Monitor”. Select the option “Output per hour” from the list of predefined options.

If the requested variable does not appear in the list, 4DScript code has to be entered. To this end, select the option 4DScript Expression from the list and click the square button to open a 4DScript Editor. You can now enter your own code. However, this is not recommended for beginners.

Now you see why we added the Queue before the Sink: to use the pre-defined statement Output per hour (a Sink has no output!).

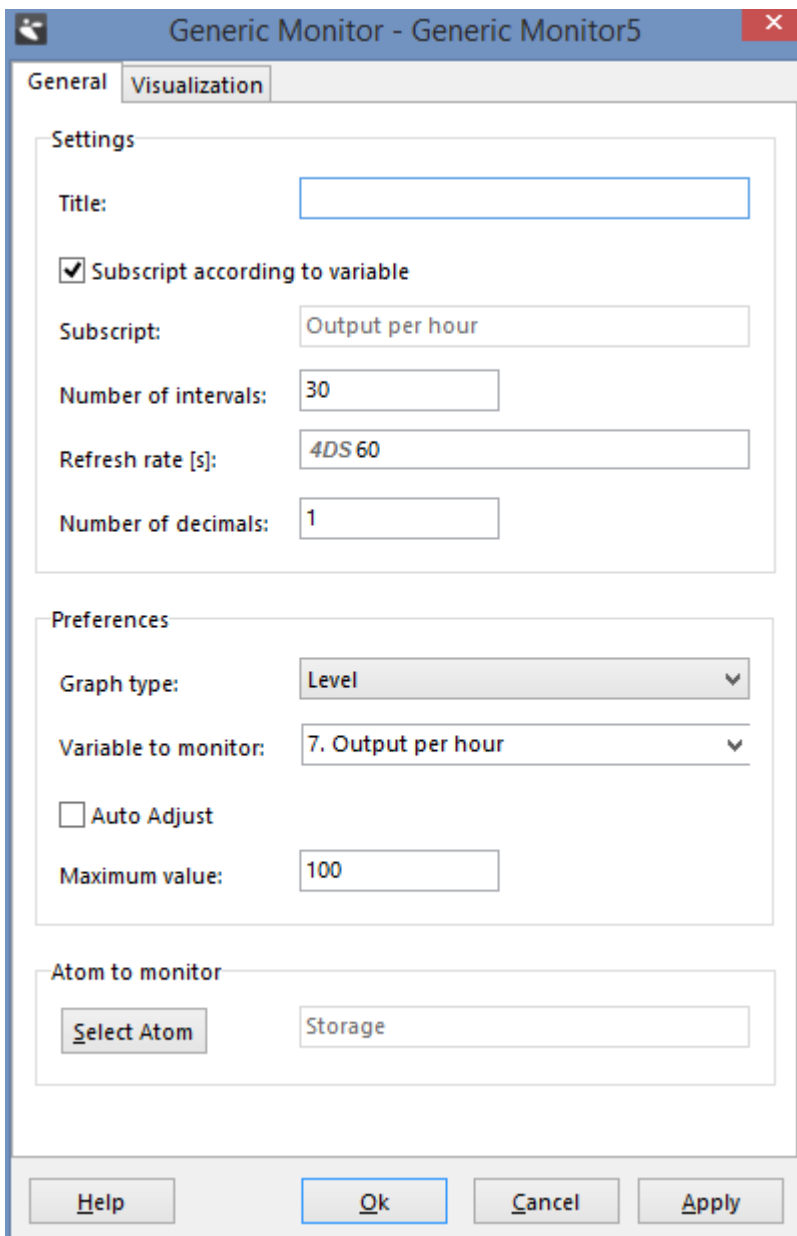

Picture 6-5: Monitor variable

Set the *Sample rate* to 60 seconds: measurements will now be taken every (simulated) minute. Because the average output is not likely to be restricted to whole numbers change the number of decimals to 1. Try *Auto adjust*, *Maximum value*, to develop a feeling for the various settings!

We choose 100 as maximum value as you can see in Picture 6-5. Now start the simulation.

 Using a large number of monitor atoms with the sample rate set to the default value of 5 seconds can be the cause of models running very slowly! Remember that the monitor atom is being displayed every 5 **simulated** seconds, and thus is taking up a lot of processing time! This phenomenon even occurs when the model layout window is closed. In many instances, a sample rate of 60 seconds or even 3600 seconds is preferable. Therefore, use the default sample rate of 5 seconds in monitor atoms with caution.

Questions and assignments

4. How many windows are leaving the factory on average per hour?

3. Summary report and graphs

A third method to measure results is to use the option 'Summary report' and 'Graphs' from the Results menu.

We will first deal with the option Summary reports. It enables you to get an overview of the status of the model,

where a distinction is made between the following features:

- Current Content:** The number of products present in an atom the moment the report is made.
- Average Content:** The average number of products that were present in the atom.
- Throughput Input:** The number of products that have entered the atom.
- Throughput Output:** The products or customers leaving the model through this atom.
- Staytime average:** The average time the products are spending in the atom.

By selecting the option Summary Report in the Results menu, a report such as in Picture 6-6 appears.

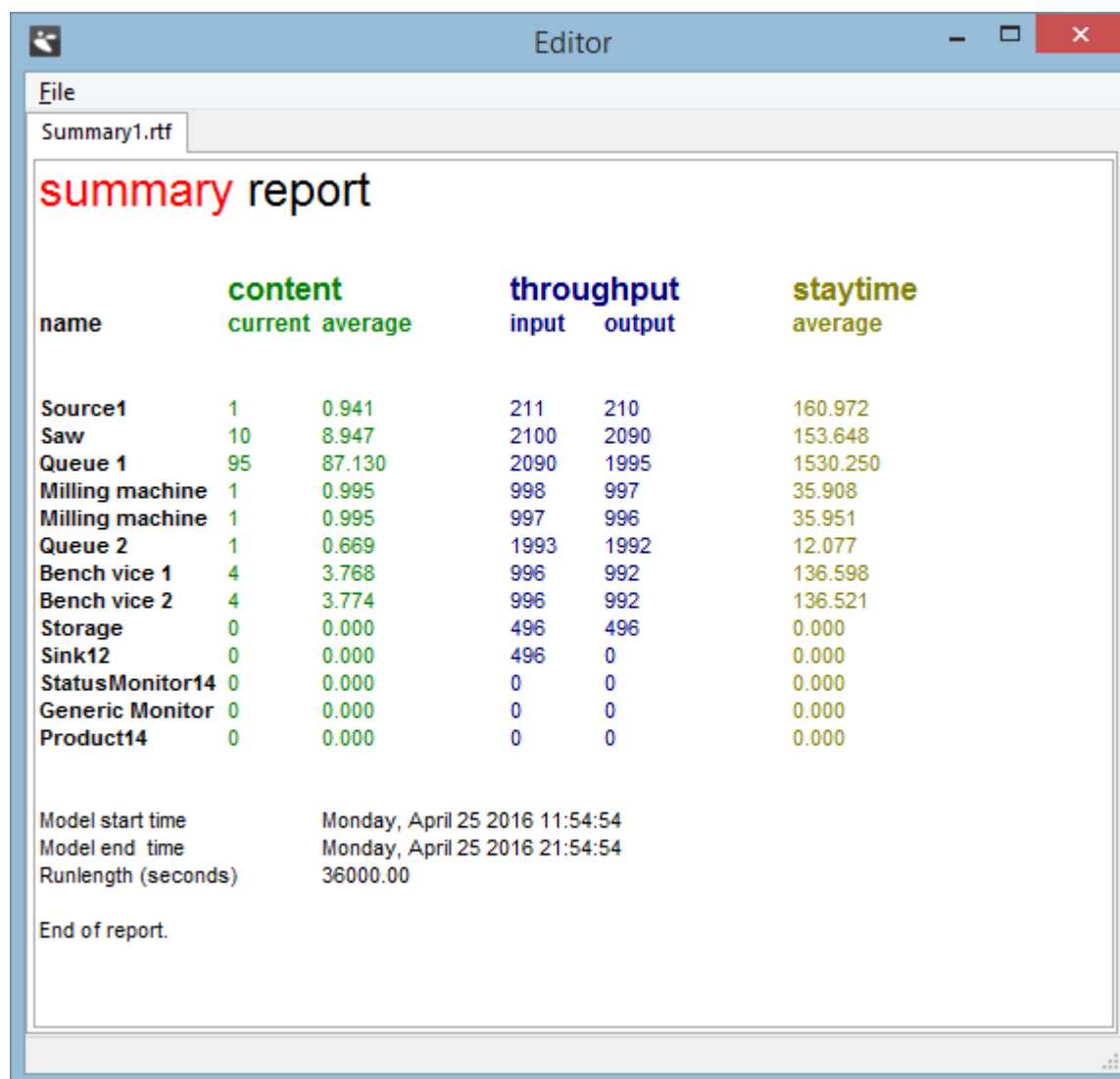

name	content		throughput		staytime average
	current	average	input	output	
Source1	1	0.941	211	210	160.972
Saw	10	8.947	2100	2090	153.648
Queue 1	95	87.130	2090	1995	1530.250
Milling machine	1	0.995	998	997	35.908
Milling machine	1	0.995	997	996	35.951
Queue 2	1	0.669	1993	1992	12.077
Bench vice 1	4	3.768	996	992	136.598
Bench vice 2	4	3.774	996	992	136.521
Storage	0	0.000	496	496	0.000
Sink12	0	0.000	496	0	0.000
StatusMonitor14	0	0.000	0	0	0.000
Generic Monitor	0	0.000	0	0	0.000
Product14	0	0.000	0	0	0.000

Model start time: Monday, April 25 2016 11:54:54
 Model end time: Monday, April 25 2016 21:54:54
 Runlength (seconds): 36000.00

End of report.

Picture 6-6: Summary report

Accordingly, you can see in Picture 6-6 that a product is present on average 36 seconds in milling-machine 1, that 992 products have been produced in bench vice 2 and that 4 products are still present there.

As you can see in the lines of the saw and the two bench vices, *all* measurements on servers with batch transitions are performed in the “smaller” unit, i.e. the units each batch consists of. For instance, look at the output of Source1 of 210, and the input of the Saw of 2100. The measurements on the saw therefore apply to short timbers rather than long timbers, and the measurements on the bench vices apply to the milled short timbers rather than window frames.

It *would* have been possible that the output (not the input) of the saw had *not* been a multiple of 10 (like 2098 instead of 2100), because Queue1 is full and is therefore blocking the entry of additional finished short timbers. In order to understand this, please realize that Queue1 will send short timbers to the two milling machines one by one).

Based on this report, measure that 49.6 windows on average per hour have been produced!

The option Graphs gives you a graphical representation of a variable. To be able to make a graph, you need to switch on the History option for the atom that you want to represent in the graph. This is done by using the History option in the Simulation menu.

Warning! The option ‘General history’ (by checking) as well as the individual atom has to be selected, see Picture 6-7. At first it might seem a good idea to turn history on for all atoms, click ‘Select All atoms’. However, recording history this way, especially for large models, will have the effect of slowing down the simulation unnecessarily.

At this stage, we will only focus on the possibility of creating graphs by means of the menu option Graphs, because the atom Graph often needs to be programmed. The Graph atom might be convenient for advanced users, because all possible variables can be defined by using 4DScript.

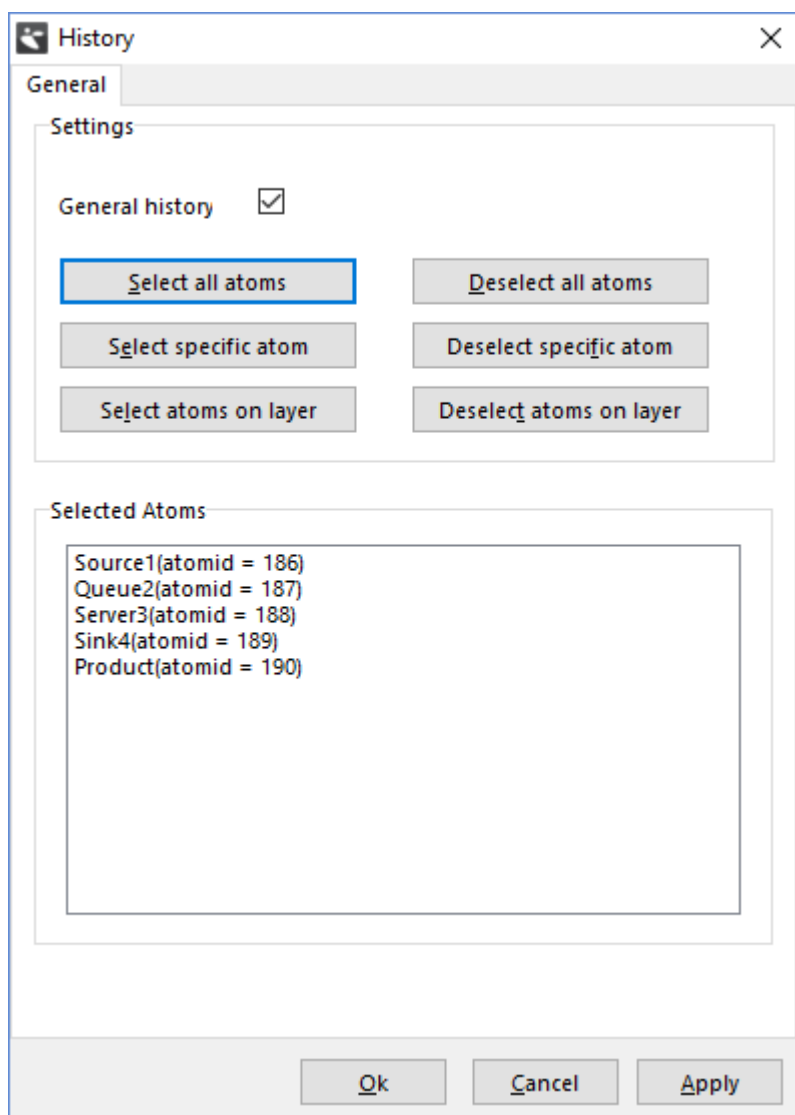

Picture 6-7: History

If the general History is switched on and some of the atoms are selected in the history window, then the run data of each of these atoms is collected. This data can be visualized with the Graph option in the results menu.

By clicking on the option Graphs in the Results menu, a window appears. In this window you can select the atom of which you want to make a graphical representation. If an atom is selected and history for that specific atom was recorded, a window such as in Picture 6-8 appears. If no atom is selected a selector window appears. In that case first choose one of the atoms for which you have recorded history.

Graph for Queue2

Graph Type	<input type="text" value="Queue Graph"/>	Graph Select a graph type. If desired you can change the time interval for analysis. Click finish to show the graph
StartTime	<input style="border: 1px solid gray;" type="text" value="4DS 0 {seconds}"/>	
Duration	<input style="border: 1px solid gray;" type="text" value="4DS time {current time}"/>	

Picture 6-8: Input window Graph

We will first go over the last two input fields:

- **Start time**
The starting time of the graph is to be entered here. If 0 is indicated, the graph will start from the beginning of the simulation run. If the value 10 is entered, then the graph will not include the first 10 seconds of the run.
- **Duration**
In this input field, you indicate how long the graph will be recorded. For example, if the value 3600 is entered here, the first hour after the starting time of the graph will be shown. The default value is “time”, the number of simulated seconds that have passed when the simulation run was stopped.

The first input field, Graph Type, is where you can select the type of graph desired. There are 5 possibilities:

1. Queue Graph

With this function, you can make a graph of the number of products present in an atom. In a Server atom, the number of products will as a rule never be higher than 1, but in a Queue atom, the queue is being conveyed in the graph. Picture 6-9 represents a graph of the first buffer from the carpenter’s factory case study, measured between 2 and 4 simulated hours after the start of the simulation.

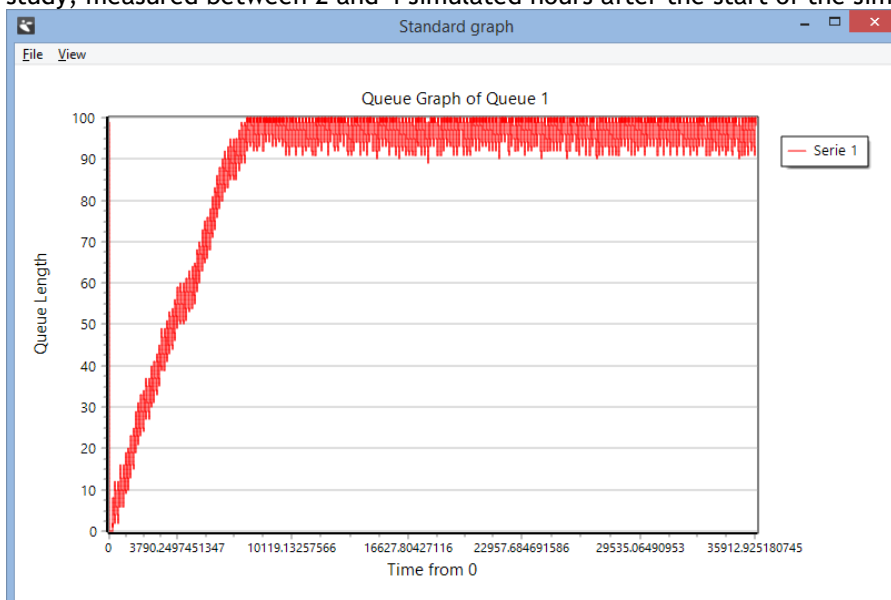

Picture 6-9: Queue graph

2. Queue Histogram

The percentage of time each ‘storage level’ takes up is reflected here.

See Picture 6-10, displaying the distribution of different queue lengths of Queue1 measured between 2 and 4 hours after the start of the simulation.

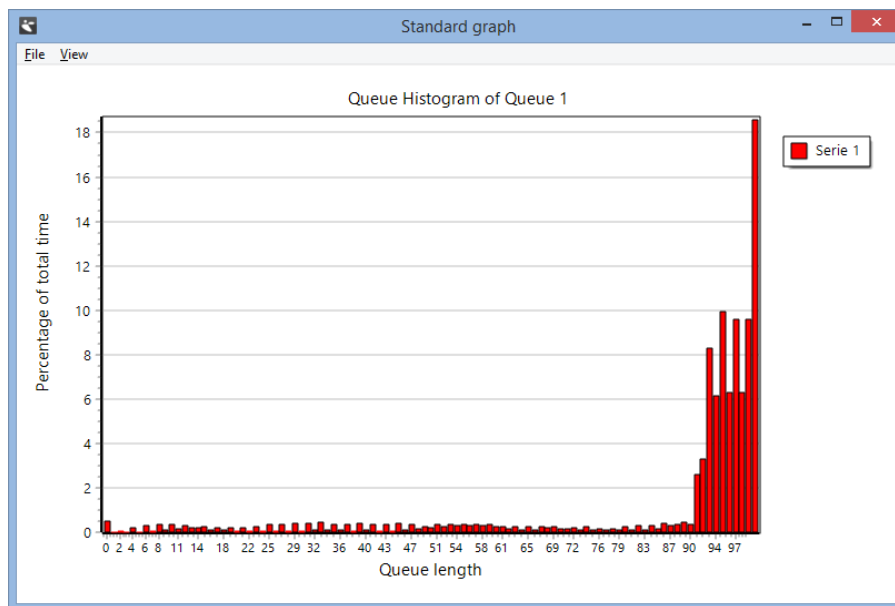

Picture 6-10: Queue histogram

3. Status Pie

This function enables you to represent the status of an atom in a pie chart. Picture 6-11 shows a Status Pie representing the status of the first milling machine from the carpenter's factory case study, measured during the first two simulated hours.

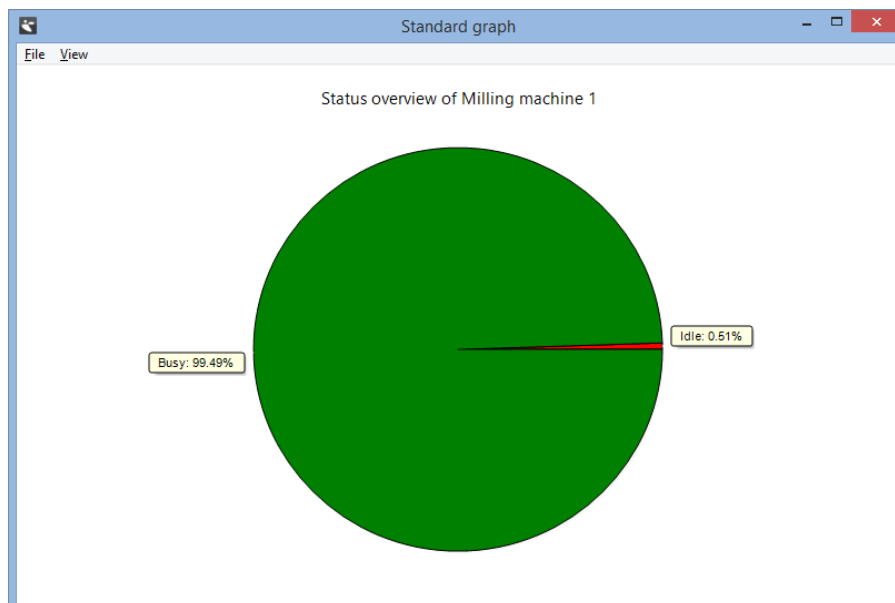

Picture 6-11: Status Pie

4. Status Bar

With the option Status Bar, the status of an atom is reflected in a bar chart. See Picture 6-12, which corresponds to the measurements displayed in Picture 6-11.

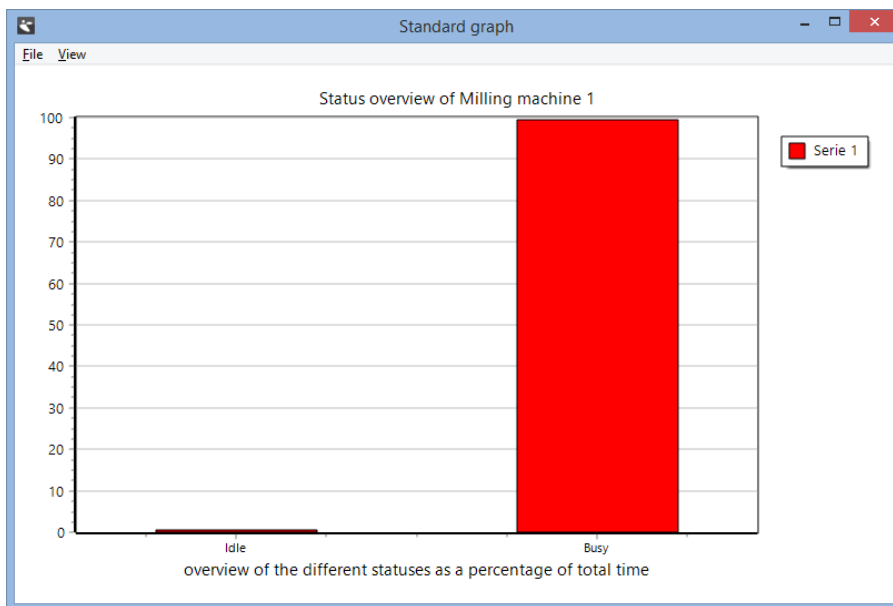

Picture 6-12: Status Bar

5. Wait Histogram

The Wait Histogram function produces a histogram about a product's waiting time in an atom. See Picture 6-13, which displays the distribution of the waiting times of the short timbers in Queue1 during the first two simulated hours.

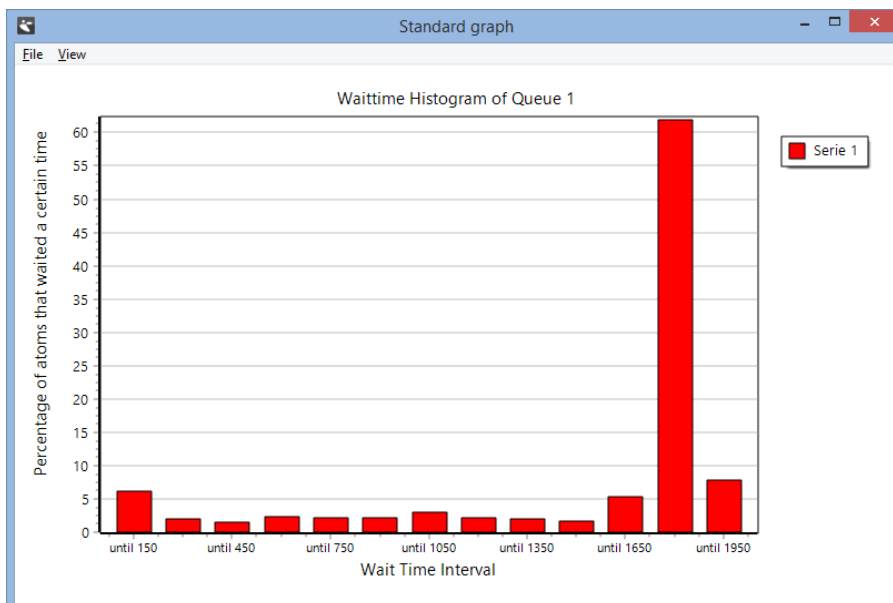

Picture 6-13: Wait Histogram

4. Setting up an experiment with the Experiment Wizard

The three above mentioned methods for measuring results are particularly useful to display results directly during the simulation. For drawing conclusions about the results of the model, these techniques are less appropriate. In this case, an experiment is the appropriate method to use. An experiment can be created with the Experiment Wizard, which can be opened from the Simulate page of the main menu.

It is important to understand the major differences between examining the results of a single simulation run with for example the Summary report, the results atoms or the Graphs option on one hand and Experimentation on the other hand: We use the first options for building and testing our model and for getting first results on *single* runs, while Experimentation is used later in the process when we trust our model and want results on *multiple* runs, because we can't draw conclusions from the outcome of a single run.

Case study assignment (continued)

Questions and assignments

5. Design an experiment with a warm-up period of 10 hours and a measurement period of 100 hours, in which the average window production per unit of time (hour, day or week or simulation period) can be determined with a 95% reliability.
Does it correspond to your calculations made beforehand and to the results gained with the other techniques to measure results?

We will demonstrate how to solve this assignment step by step.

Basically, there are four steps in experimentation:

Step 1 Definition of the Experiment Settings

Defines experiment settings such as the number of runs, the length of the observation period, the warm-up period, etcetera.

Step 2 Definition of the Performance Measures

Define the performance measures of atoms or a group of atoms.

Step 3 Experimentation

Running the experiment according to its definition. This step requires no action from the user!

Step 4 Report definition and analysis

If the sample rate of your monitor atom is still set to 60 seconds, or even worse 5 seconds, this might be a good time to set it to 36000 seconds (10 hours), or even 1E9 (1 billion seconds, about 32 years), since you will not need the monitor atom during the experiment. It will make your model run considerably faster during the experiment. Click on Experiment Wizard on the simulation page of the main menu, a window appears, see Picture 6-14. Start with giving the required values for the observation period, number of runs and the warm-up period in the Experiment Setting, see Picture 6-14. If you are finished, you can click Next.

We are now ready to define the Performance Metrics (PFMs). In the 'Edit Category Window' click Add to create a new performance metric, see Picture 6-15. We are interested in the capacity per hour of the production system. We can measure this by measuring the number of products that enter the Sink. The output of the system can thus be measured by measuring the input of the Sink. To define a PFM on the Sink first click 'Select Atom' and select the Sink. We still need to define what we would like to measure at the Sink. Therefore click Add in the Performance Metric section. We can now enter a name and select a performance metric from the list.

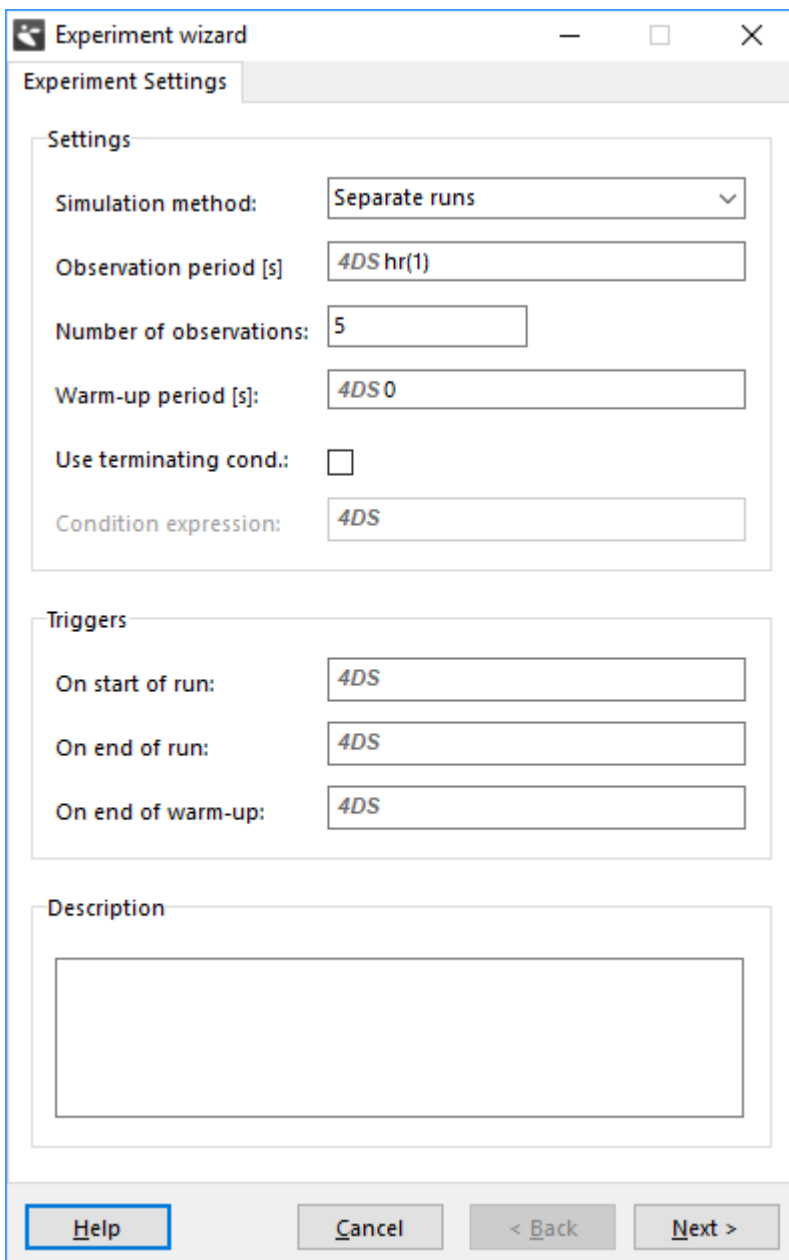

Picture 6-14: Experiment Settings

Define a PFM on the Sink named `Produced per hr`, see Picture 6-15. The input during the 100 hours is divided by 100 to get the number of windows per hour. Make sure you select the “[USER DEFINED]” option for your PFM, and do not forget to remove the string “[USER DEFINED]”, and type `Input(cs)/100.cs` in the 4DScript code for the current selection, (which can also be a group of atoms).

If both the name and the PFM are entered click Ok. Click Add again to define another PFM on the Sink. In this case we only need a single PFM thus we can click again on Ok. We can click Add again if we need to define another PFM on a different atom. Click Next after all PFM have been entered.

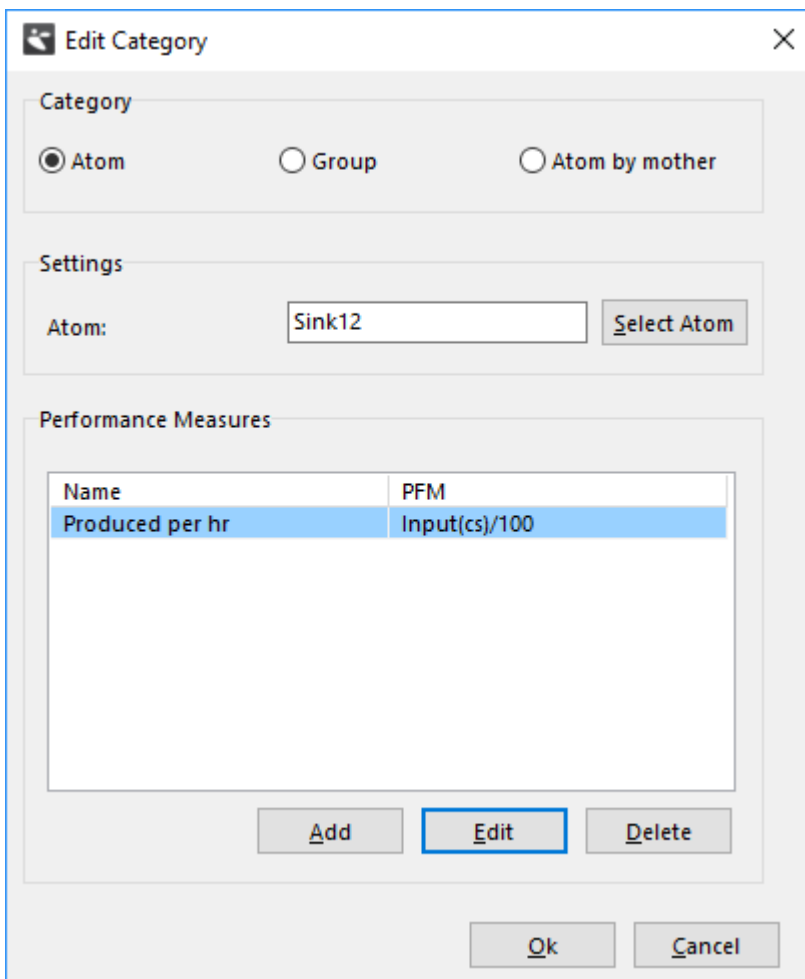

Picture 6-15: Definition of the PFM

The actual running of the model -after start experiment- is done in step 3, see Picture 6-16 and may take some time: In every run of 100 hours about 500 windows have to be made from 2000 short timbers and 200 long timbers!

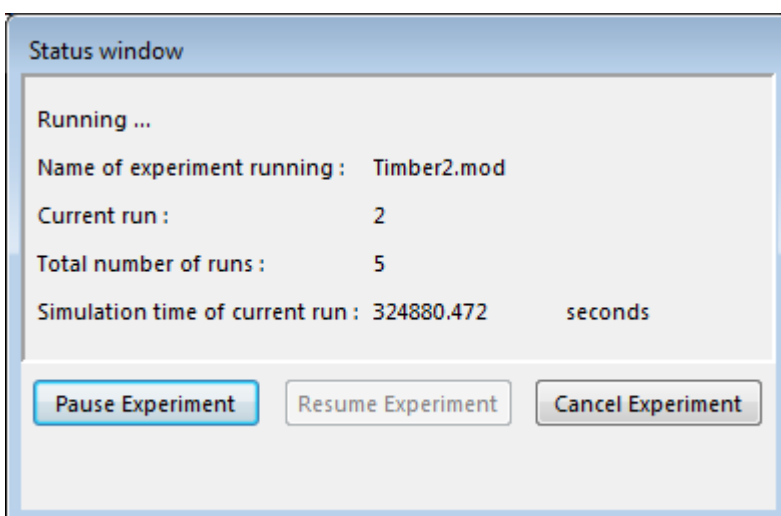

Picture 6-16: Experiment Settings

After running the experiment it's easy to make a report, see Picture 6-17. From this table the results can be exported to Excel (click 'save as .csv') or put in a report via Quick Report (click 'Preview').

Results Table							
Observation period :	18000						
Warmup period :	0						
Number of observations :	5						
Simulation method :	Separate runs						
Description :							
Atom :	Sink12						
		Average	St.Deviation	LB (95%)	UB (95%)	Minimum	Maximum
Produced per hr		0.00	0.00	0.00	0.00	0.00	0.00

Buttons: Help, Close, Save as .csv, Preview

Picture 6-17: The Results Table

This concludes our example about experimenting. For a thorough examination of what is possible we refer to our document on experimentation, see Help | Tutorials.

The model with this experiment is supplied under the name timber2.mod

7 Playing with Strategies

In this chapter, the emphasis lies on the pre-defined strategies with which products get access to a next atom (input strategy), are selected out of a queue (queue discipline) and are re-directed after processing (send to).

To demonstrate this, a simple model has been built. It consists of three Sources, three Locks (an atom regulating the products' supply), five Servers, four Queues and one Switch, which is a self-built atom (Enterprise Dynamics offers this flexibility). The purpose of this atom is to switch the Servers on and off. There is no Sink; consequently all products remain in the last Queue, see also Picture 7-1.

The model is supplied under the name `strategy.mod`.

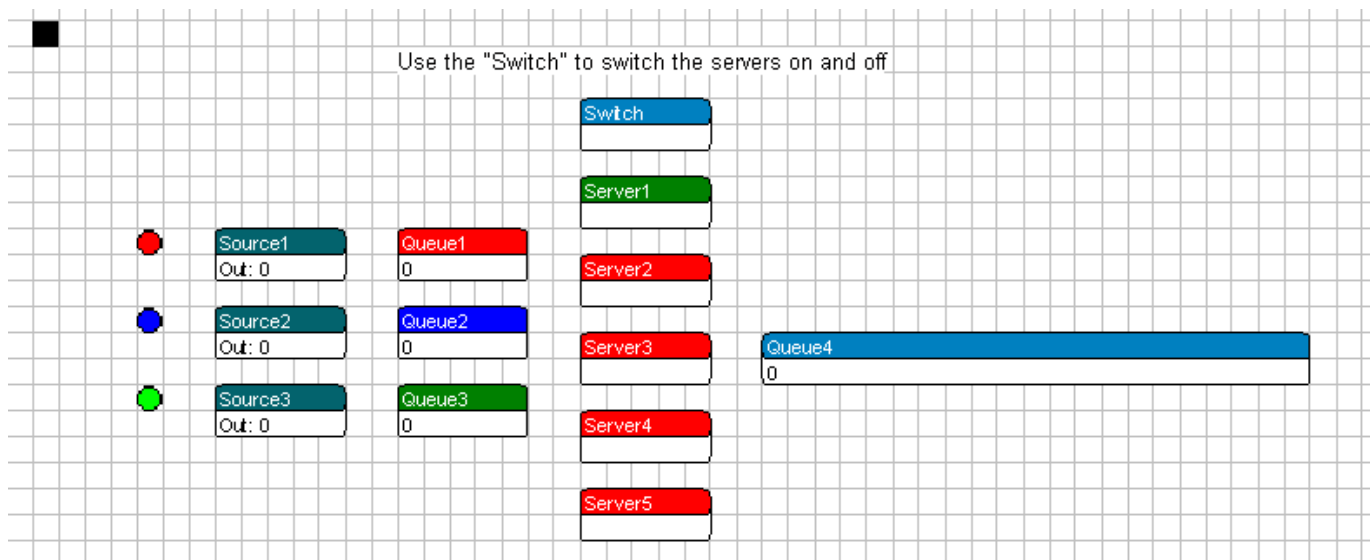

Picture 7-1: The layout of `strategy.mod`

Warning: Because the source code of the last queue atom has been adjusted and a new designed atom is used, beginners will not be able to build this model on their own. Advanced users can however build this model by using the standard atom and adjusting the code on the 2D Draw event handler on the last queue so that it can show up to 100 products in it. The atom behavior can be changed from the Atom Editor. Because the Switch is also not a standard atom, advanced users will have to switch the servers on and off manually. This is possible with the Availability Control atoms, among others.

From the three sources, three types of customers arrive at the queues. Their arrival is regulated in such a way that the three queues will get filled rather quickly. We have set the option 'Number of products' on each of the sources to allow only 10 of each type of customer to leave the source. From the queue, the customers are helped by a server and after that end up in the last queue. The role of the *switch* is to switch the servers on and off.

In principle, all servers can be reached from the three queues, the first server can always be reached through channel 1, the second through channel 2, etc. However, in the original settings of `strategy.mod`, only server 1 has been switched on (by means of the switch). As a result, during a simulation, the first server is colored green while the others turn red. In addition, the default parameters are applied, which means that:

1. all input strategies are still on *Any input channel*,
2. all queue disciplines are still on *First in first out*,
3. all send to on the Queues are set to 4. A random open channel: choose a random channel from all the open output channels. This means every Server available can be the next station from a Queue.

The products and their icons are visible in the last queue. As a result, the order in which the products have entered the queue is accurately visible (provided the queue discipline is set on FIFO).

Because the products receive a *label* when leaving the source, they can also be sorted out in the last queue on the basis of this label. Labels can be thought of as tags hanging on a product. They can represent a color, a weight, a size or something similar. They are defined in 4DScript, Enterprise Dynamics' programming language, and play an important role in most models.

Look at the other parameters of `strategy.mod` and carry out a few simulation runs to find out more about it.

After that, we are ready for experimenting with strategies...

7.1 Adjusting the input strategy

The input strategy regulates the access to an atom from preceding atoms (i.e. those with an output channel connected to one of its input channels). The role of the input strategy is to define the order in which products will be accepted from the available channels.

You can think of the input strategy to the sequencing of traffic lights where some roads have a greater proportion of time at Green than more minor roads.

The first three input strategies open all input channels and the last two open one input channel each time.

As an exercise, we are now going to look at the effect of the input strategy change on server 1 in the unaltered initial model. Change the input strategy as specified below and consider what is happening to the performance of the systems after observing a few runs.

1. *Any inputchannel*

When activated, this strategy opens all input channels of an atom. If more than one of the atoms that are connected via the input channel can be forwarded, the atom with the lowest number as input channel will have priority. As long as the products keep entering through the first channel, the other channels will be blocked.

2. *Largest queue*

When activated, this strategy opens all input channels of an atom. If more than one of the atoms that are connected via the input channel can be sent, the atom with the longest queue or largest contents will have priority. Note that in the case of several equally long queues, the input channel with the lowest number is always chosen.

3. *Longest waiting*

When activated, this strategy opens all input channels of an atom. If more than one of the atoms that are connected via the input channel can be sent, the atom with the highest waiting time will have priority. In the case of several atoms with an equal waiting time, the input channel with the lowest number is always chosen. Note that it does not mean that the queues get approximately equally long, as is the case in the previous option.

4. *Round robin*

This strategy first opens the first input channel and then waits for a product to be sent through this input channel. In the second cycle, it is the turn of the second input channel etc. When the products have run through the last input channel, the procedure is resumed with the first one.

 This strategy becomes active after the first product! So, in case of three input channels this strategy gives x,2,3, 1,2,3, 1,2,3 where x can be 1,2 or 3!

5. *Round robin with content check*

This strategy is similar to the Round Robin, with that distinction that when the atom connected to the desired input channel has no content, the next will be checked. When none of the incoming channels has something to hand over, the strategy will wait for the first channel that will offer something and will continue from there on.

 This strategy becomes active after the first product! So, in case of three input channels this strategy gives x,2,3, 1,2,3, 1,2,3 where x can be 1,2 or 3!

6. *Channel 1.*

In this case, you can enter a specific input channel through which all products must enter. If 1 is entered, the products may enter only through input channel 1. Note that this rule is not valid for the first product entering as all channels are open initially.

7.2 Changing the Queue Discipline

The purpose of this section is to change the Queue Discipline of the last queue and to observe the consequences.

Change the input strategy on the first server to Largest Queue. This will ensure that the products enter with as much disorder as possible. Leave the other four servers switched off, because when five servers are switched on, it is harder to see how the atoms are moving. The six possible parameters are mentioned below:

1. *First in first out*
The atoms are put in the queue according to their order of entry.
2. *Last in first out*
The entering atoms are placed at the front of the queue. Consequently, the products leave the queue in reverse of their order of entry.
3. *Random*
This queue discipline places the incoming products in a random spot in the queue.
4. *Sort by Label Ascending*
The products with the lowest value for a specific label are placed ahead in the queue. Test this option by sorting according to 'product' label, which is specific to all product atoms of this example. *Warning:* if the products are not sorted properly, the cause might be a space before or after the label name.
5. *Sort by Label Descending*
The products with the highest value for a specific label are placed ahead in the queue.
6. *User defined*
The products are placed in the queue according to a position defined by the user. Try this out for the value 5.

7.3 Adjusting the Send to Statement

In this third part of the case, we will discuss a number of 'Send to' statements for the three queues towards the servers. With the 'Send to' statement, we define the output channel through which a product is to be sent. The user can enter a figure or select one of the 21 (!) pre-defined options. For a complete overview of the Source atom description, we refer you to the help documentation.

First, we switch on the five servers; otherwise there will be little to send. This will give them the color 'green' and allow the products to pass through.

Try out the following settings on the queues:

1. *Specific channel: always send to channel 1.*
The Product Atom will always be sent to a defined output channel. Enter for example channel 3.
2. *An open channel (First channel first): search, starting from the first channel, and send to the first open channel found.*
The Product Atom is sent to the first open channel that Enterprise Dynamics finds. The search starts from the first output channel (channel number 1).
3. *An open channel (Last channel first): search, starting from the last channel, and send to the first open channel found.*
The search starts from the last channel and the product is sent to the first open channel Enterprise Dynamics comes across.
4. *A random open channel: choose a random channel from all the open output channels.*
Enterprise Dynamics selects a random channel. With long simulation runs, it results in equal utilizations of e.g. a group of servers.
5. *By percentage: 90% of products go to channel 1, the remaining percentage go to channel 2.*
A definite percentage of the products are sent to a specific channel and the rest to another channel. The user can enter the channels and the percentage. Try to send 75% to server 1 and the rest to server 5.
6. *By user: enter your own 4DScript expression resulting in a value between 1 and the number of channels: 1. You can press the small button for the 4DScript editor.*
The user writes a 4DScript code that results in the output channel. By clicking on the small triangle next to the text, the 4DScript editor appears. For example, enter 2.

This concludes the example relating to the strategies. Of course, there are many other possibilities, which can be defined using 4DScript, Enterprise Dynamics's underlying programming language.

8 More Atoms from Assembler to Unpack

In the previous chapters, we described the basic atoms. Subsequently we practiced model building and experimentation with simple models. In this chapter, we will introduce eight new atoms, that can be used to model complex situations. Furthermore, we will address the visualization possibilities in Enterprise Dynamics in more detail.

The atoms described in this chapter are:

1. *Assembler*
This atom is used when several atoms are assembled in a new atom. The old atoms can remain stored (packed) or destroyed (assembly).
2. *Unpack*
This atom can disassemble previously assembled atoms. If, for example, a container was filled using an Assembler, the Unpack atom can unpack it again.
3. *Container*
The Container is an atom for storing or packing products. Examples are a box or pallet.
4. *Accumulating conveyor*
The Accumulating conveyor is a transport system that also functions as a buffer. If the load in front of the conveyor is blocked, then loads will continue to move forward until their progress is blocked by another load that has accumulated. The Accumulating conveyor is used for modeling roller conveyors.
5. *Non-Accumulating conveyor*
The Non-Accumulating conveyor is very similar to the Accumulating conveyor, but does not continue to move products forward if progress is blocked. The distance between products thus always stays the same. The Non-Accumulating conveyor is used for modeling chain conveyors.
6. *MultiService*
The MultiService atom functions as a group of parallel Servers: it has the basic functionalities of the Server atom and allows the simultaneous processing of several products or individual product processing.
7. *Lock*
The Lock atom lets only a pre-defined number of products through. All following products are blocked.
8. *Unlock*
When a product exits the Unlock atom, the Lock atom can allow a new product through. This makes it possible to control the amount of work in process in the model or the number of transport means.

All the above atoms are described in the following example.

Example 3: Stacking and wrapping

In the dispatch department of a factory, products are stacked on a pallet. The products and pallets arrive via two separate conveyors at this pallet stacker or pallet-stacking robot. This robot can stack the products on top of each other as well as next to each other, irrespective of their size.

From the robot, the pallet stacked with products moves via the next conveyor to a wrapping machine, which wraps the products in plastic. The wrapping machine can wrap the products from several pallets simultaneously or independently of each other.

The system is made up of the following elements:

1. Every 5 seconds, a product arrives at the pallet stacker via a roller conveyor.
2. Via a second roller conveyor, one pallet on average arrives every 40 seconds, according to the negative exponential distribution.
3. The pallet-stacking robot always places 8 products on the pallet and needs exactly 20 seconds per pallet, provided all products are present.
4. A chain conveyor transports the full pallets to the wrapping machine.
5. The wrapping machine can wrap a maximum of 4 pallets simultaneously in plastic foil. For each pallet, an average of 120 seconds is needed (using negative exponential distribution) to wrap the products on the pallet in plastic.
6. The length of each conveyor has no bearing on this matter: select one of about 10 meter's length. The speed is always 1 m/s. The products are 50 cm in length, width and height and the pallets are 1 meter long and wide.

We want to model this system in Enterprise Dynamics: for the roller conveyor we use an Accumulating conveyor, for the chain conveyor, we use a Non-Accumulating conveyor. Further, for the pallet stacker we use the

Assembler, for the wrapping machine, the MultiService atom, and for the pallet we use the Container.

But... before you start, work out quickly whether this system would be able to handle the incoming load!

Most atoms can be placed in the model without problems because they are connected with other atoms in a normal manner.

With the Assembler, the pallets must enter the atom via the first channel (visualized by a small square) and the products must enter via the second channel.

Double-click on the Assembler to define the number of products per pallet. This will display an input window with various tab sheets. The General tab sheet allows you to enter, for each entry channel, how many atoms are to be assembled by pushing the button “Edit B.O.M. table”, see Picture 8-1. The help included with the software can be referenced for a full description of all atoms used, including the Assembler itself!

The Assembler stacks the products on the pallet automatically. The space reserved for each product is defined in the Container atom. In order to avoid having all products stacked on top of each other in one high column, the size of the product must be adjusted in the Product atom. To this end, see the solution worked out in Example 2!

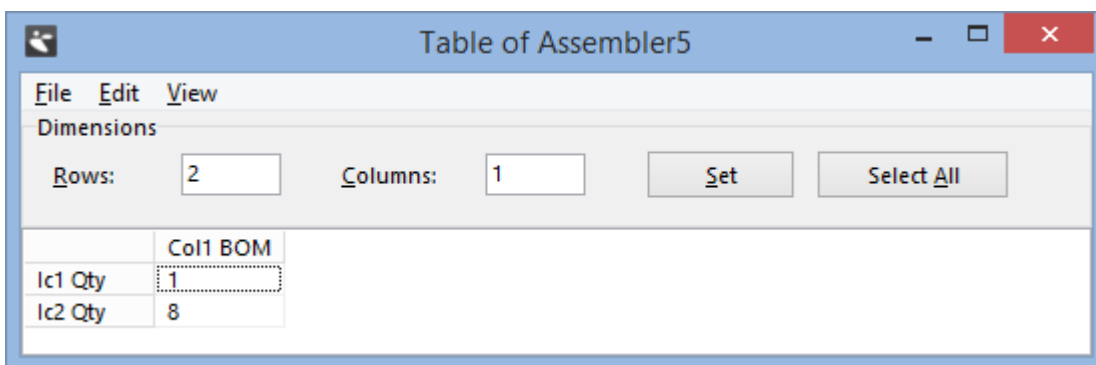

Picture 8-1: Bill of Material of the Assembler

When all atoms are placed in the model, the layout of the model will look like the one shown in Picture 8-2.

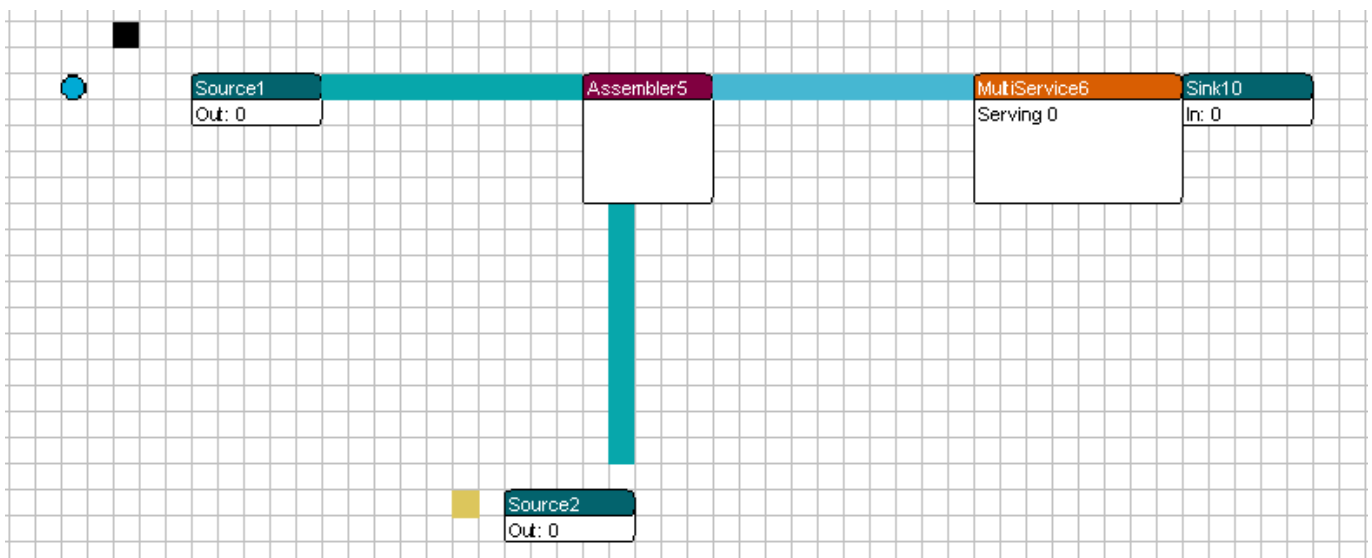

Picture 8-2: Layout of the conveyor system

Save your own model. If you are not sure that your own model is correct, you can also use the model supplied under the name conveyor1.mod in the following sections.

Let the system run for a while and see how it works in 3D. Play around with the sizes of the products or the Container and see what happens! Do the same with the speed of the conveyors or the processing times: for example, defining a much longer processing time of the MultiService atom will cause a buildup for the wrapping machine, and give you a clear picture of how the Non-Accumulating conveyor works.

Questions and assignments

1. For controlling the workload, we do not want to work with more than 5 pallets at a time in this system.

Please adjust the model accordingly.

This is achieved by placing a Lock and an Unlock atom in the model. The Lock and Unlock atoms are inserted in the middle of the production process: The Lock atom is inserted at the spot where the restriction starts, the Unlock atom, where it ends. The Lock atom shuts down by itself after a pre-defined number of atoms have gone through. The Unlock atom reverses the blockade.

By inserting a Lock atom alone, no more than e.g. five atoms can enter the system. By inserting an Unlock atom as well, we make sure that no more than five atoms are present in the system at the same time. The Lock atom is always placed behind the Source, because the Source would otherwise regard the Lock atom itself as a product and send it into the system. The Unlock atom is always inserted at the spot where the restriction of the number of atoms has to end again, e.g. behind a certain machine or just in front of the Sink. In this example, the Unlock would thus have to be placed directly in front of the Sink.

By inserting an Unlock atom, the Lock atom will open automatically when an atom leaves the Unlock atom. The Lock and Unlock atoms are connected automatically with another. However, should it become necessary to connect them manually, then the second output channel of the Lock atom must be connected with the second input channel of the Unlock atom. To see more clearly how the Lock and Unlock atoms work, the Lock atom can be set temporarily to close after 1 or 2 pallets already.

Adapt the model now or open the file named conveyor2.mod

Questions and assignments

- The company now wants to separate the pallets from the products after the wrapping process and move them back to the pallet stacker using an additional conveyor system. The number of pallets in the system stays limited to 5. Adjust the model accordingly.

To make re-use possible, two major adjustments have to be made: a) separation of product and pallet, and b) transporting the pallets to the Assembler. For separating the pallet from the products, the Unpack atom is needed. Placed behind the MultiService atom, it sends the products to the first output channel and the pallets to the second output channel. By connecting a roller conveyor to this second output channel and connecting it to the existing roller conveyor, the pallets can then be re-used.

As the pallets no longer leave the system, the Unlock atom is superfluous. We could also leave the Lock out and set Number of Products to 5 on the Source. When the extra roller conveyors are included in the model, it could look like the one illustrated in Picture 8-3 and Picture 8-4 (conveyor3.mod).

The length of the conveyors is set in a way, which facilitates an immediate visualization of the pallets' cycle.

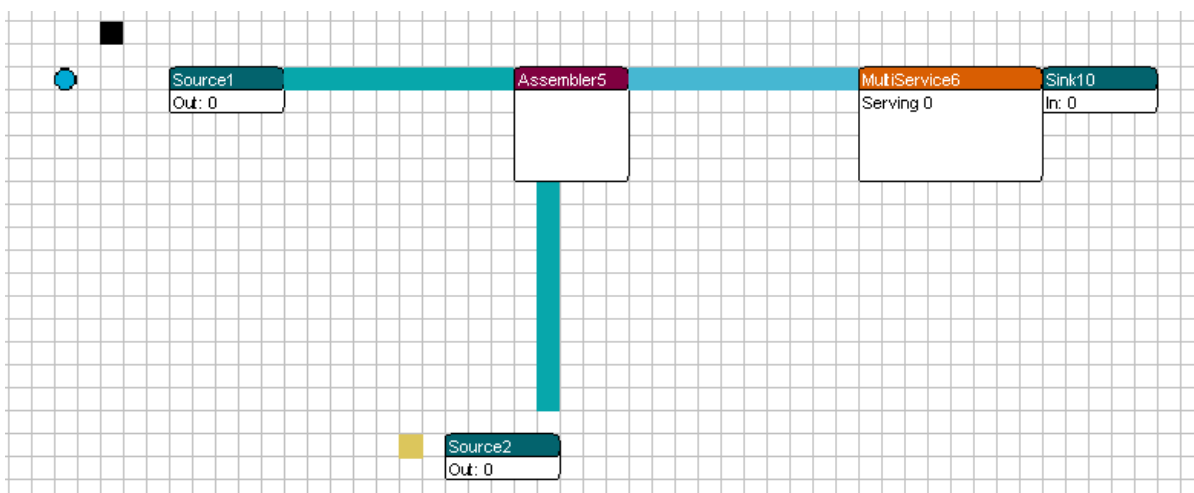

Picture 8-3: Re-use of pallets in 2D

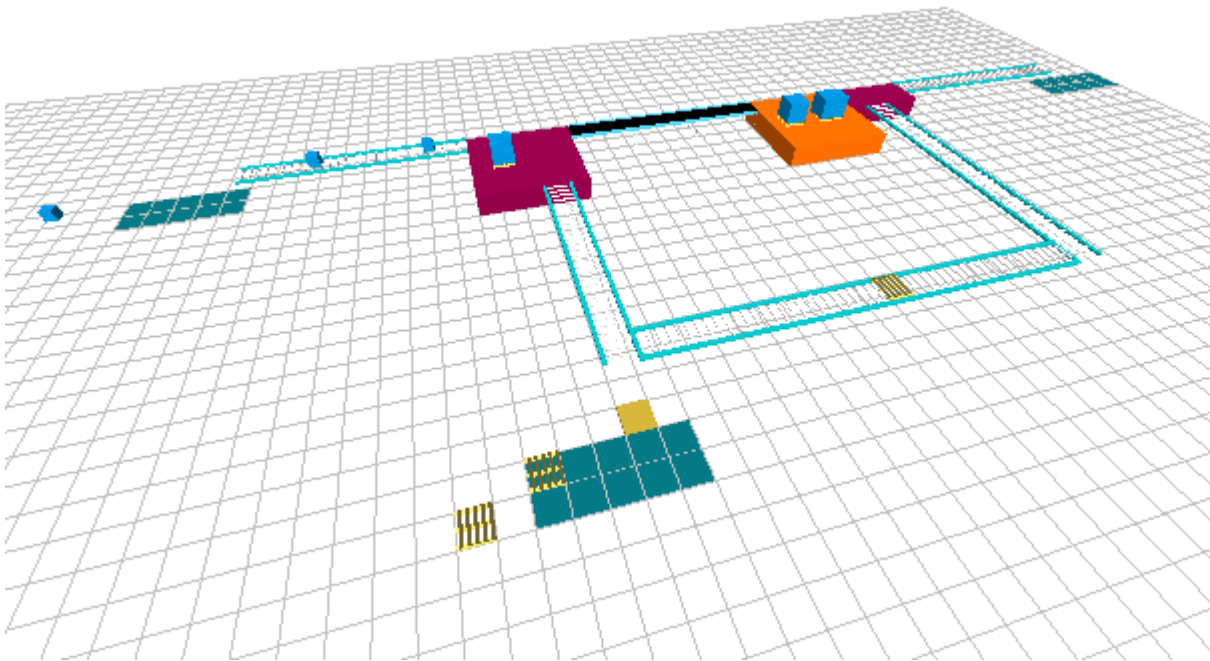

Picture 8-4: Re-use of pallets in 3D

Instead of straight conveyors you could also use curved conveyors. In Picture 8-5 the layout is mirrored. The picture shows curved, height-adjustable conveyors.

Both models can be found under the name conveyor3.mod and conveyor4.mod respectively.

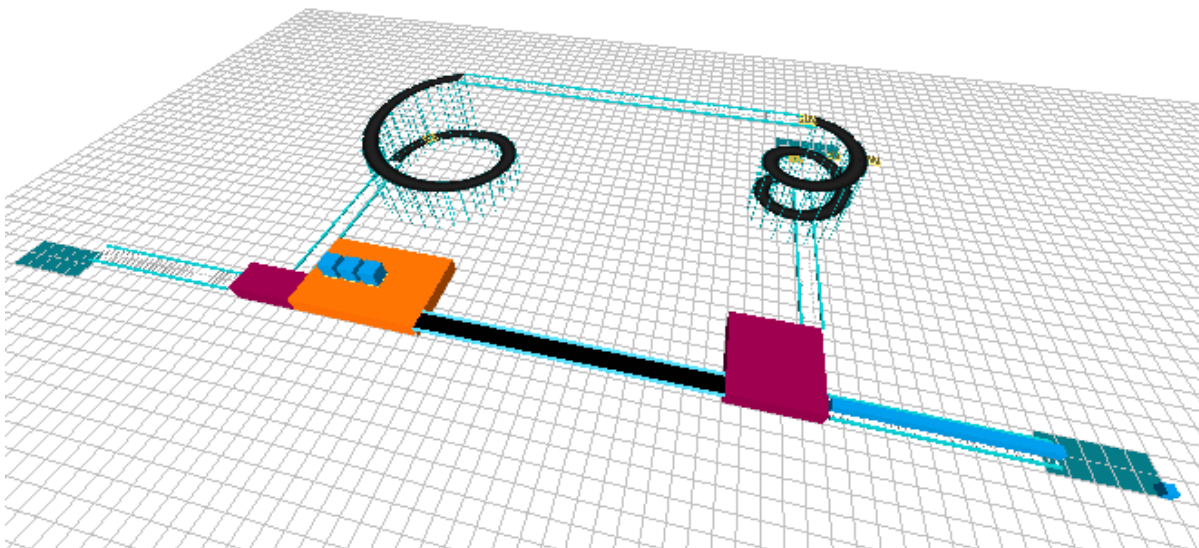

Picture 8-5: Height-adjustable conveyors

We end with a few questions regarding conveyor3.mod.

Questions and assignments

3. How much time does an average pallet cycle take (excluding waiting times)?
4. Too few pallets in the system limit the hourly production, while - from a certain moment - extra pallets have little, if any, effect on the hourly production. Explain! Determine the optimal number of pallets in the system through experimentation. Hint: Examine the average hourly production via a GenericMonitor on the conveyor before the Sink and vary the number of permitted pallets with the Lock or the Source.

9 Enterprise Dynamics and Excel

Enterprise Dynamics has the ability to access other software programs such as Excel, Word or Access for importing or writing files to disk. In this chapter, we will discuss a frequently used link between Enterprise Dynamics and Excel by building on the earlier post office example.

We will further introduce a number of 4DScript commands and the important concept of *labels* in Enterprise Dynamics.

By the end of this chapter, the user will have learned to access Excel and, moreover, will master the first basics of 4DScript.

9.1 The bank

Example 4: The Bank

A bank in Rotterdam functions as experimental subject for testing new customer processing concepts. There are several customer types with different service times.

For illustration purposes, we will limit the number of customer types to two in this example, so that 50 customers on average per hour, with a service time of 1 minute, arrive at the bank. We will indicate these customers as type A customers. In addition, another 5 type B customers arrive on average per hour, with a service time of 10 minutes.

There is one single queue for both customer types, which is serviced by two counters, according to the ‘first come, first served’ principle.

The assumption is that all arrival processes are exponentially distributed and that all service times are constant.

Questions and assignments

1. How high is the utilization of this system?
2. Applying the queuing theory, measure the average waiting times and queues, if both customer types had their own queue and counter (server).
3. Can you also make an estimate of these characteristics for the system with the single queue? Why so, or why not?
4. Which of the two systems would have the shorter average waiting time? Support your answer with arguments!

Try to answer these questions. The questions are of interest from a theoretical viewpoint; we shall return to them later. Users who are not familiar with the queuing theory on M/D/1 and M/D/2 systems can skip question 2 and 3.

For now, let’s first build the model with the single queue. After that we will connect with Excel. See Picture 9-1 for the layout of the model with the channels.

To distinguish between the customers, type A customers are represented with a blue dot and type B customers with a red one.

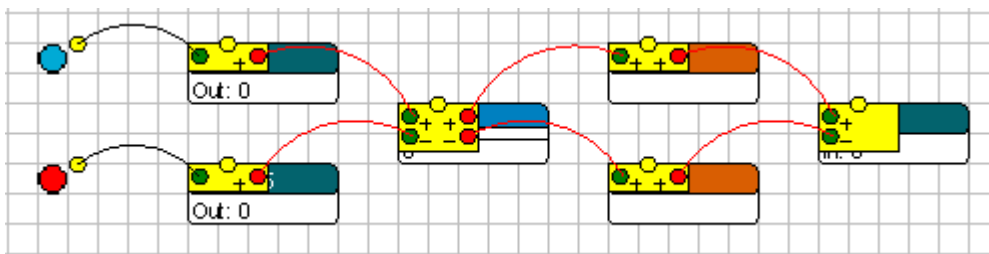

Picture 9-1: Layout of the bank

The time needed by the bank assistant to help a customer must now be set on the Server. This service time, however, depends on the customer type, meaning that there is a choice between several formulas!

This problem can be solved by using *labels*. Labels can be seen as (price) tags, the kind that are - usually - hanging on a product. Labels can represent a color, a weight, a barcode or a service time. A product can have several labels attached and the number of labels per product can differ as well.

In this example, the idea is to set the service time at an early stage and ‘attach’ this time to a label that

indicates when the service time starts. The great thing about this concept is that it is not necessary to check for customer type on the Server, but only for customer label. Moreover, this concept can easily be applied to three or more customer types!

We hang a label named `servicetime` on each product on the 'Trigger on Exit' from the first and second Source respectively. This label contains a value for the correct `servicetime`:

```
Label([servicetime], i) := mins(1)           for type A customers
Label([servicetime], i) := mins(10)        for type B customers
```



Important!

For more insight into the syntax and the structure of 4DScript, [this](#) would be the time to work your way through the tutorial 'A first start in 4DScript'.



Double clicking on fields into which 4DScript can be entered, activates the 4DScript editor. The F2 key gives access to a list with 4DScript commands, including a short explanation of each command.

The required label is called up in the cycle time of the Servers and used as service time:

`Label([servicetime], First(c))`. So, instead of entering a number directly, a 4DScript command is used which produces a number.

Read the tutorial 'A first start in 4DScript' for the syntax of the Label command and an explanation of the meaning of `First(c)`.

The complete model can be found under the name `bank1a.mod`. This model can easily be converted to a system of separate queues (`bank1b.mod`).

Questions and assignments

- Estimate the average waiting times in both systems based on a number of 100-hour runs. Do the answers correspond with your intuition?

9.2 The link with Excel

Instead of relying solely on the statistics in Enterprise Dynamics, we export the raw data such as waiting times and throughput times to Excel. With the analyses options in Excel we can then determine e.g. averages.

General procedure

- Create a new Excel file in the same directory as your model.
In most cases this will be in your Documents: `...\Documents\Enterprise Dynamics\Models`.
In this example, the file is named `bank.xls`.
- Drag the `ExcelActiveX` atom into the model. This atom can be found in the library under the category 'Data'. This atom then 'organizes' the link between Enterprise Dynamics and an Excel workbook. The `ExcelActiveX` atom does not need to be connected via channels with other atoms.
- Double-click on the `ExcelActiveX` atom. The following screen appears:

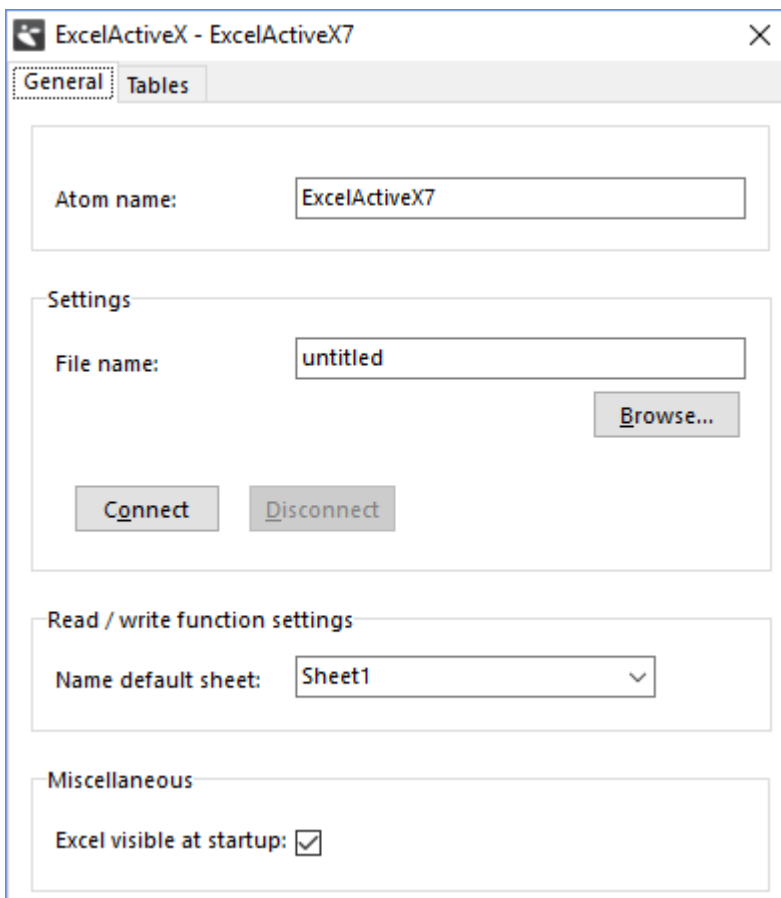

Picture 9-2: The input of the ExcelActiveX atom

Browse to select the newly created Excel file or to look up an old one. Once you're ready, click on Connect. The Excel file opens and the Excel icon appears on the task bar. Now you can select the default worksheet of the Excel file. The name of the Enterprise Dynamics worksheet must correspond with the name of one of the worksheets in the Excel file! The `ExcelActiveX_Read` and `ExcelActiveX_Write` function will read from and write to the default sheet if no sheet is given as a parameter. Switch 'Excel visible at startup' on to see Excel on the background of Enterprise Dynamics.

The link has now been established and - when zoomed out far enough - can be seen in the Excel atom. Closing the model also disconnects the link with Excel. Re-opening the model automatically establishes the link; steps 1 to 3 therefore do not have to be repeated manually each time!

If everything has gone correctly, the following layout has been created:

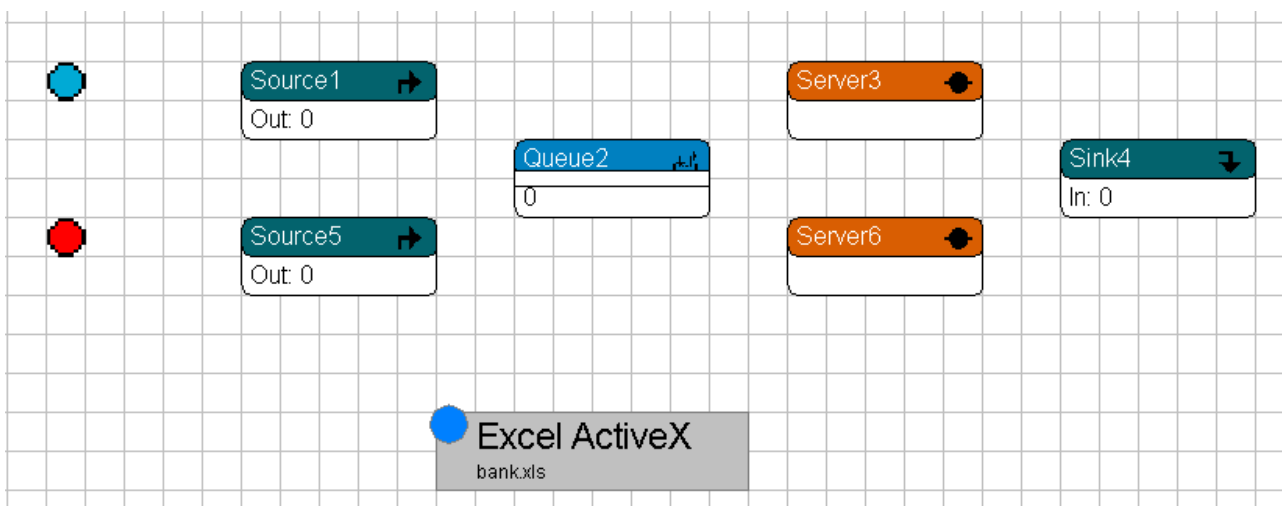

Picture 9-3: Model of the bank with an Excel link

9.3 Writing data to Excel

To see how the link works in this example, we write each customer's waiting time to Excel. This is done using the following command on the 'Trigger on Exit' of the Queue: `ExcelActiveX_Write(Output(c), 1, Age(i))`.

`ExcelActiveX_Write(a,b,c)` writes the result of expression `c` to cell(`a`,`b`) of the default sheet in the Excel file. The `Age` command keeps track of a product's age from the time of its arrival in the model. Here, this arrival time is measured from the moment the product leaves the Queue and therefore matches the waiting time of the product! The `Output` command indicates how many products have gone through the respective atom at that moment and functions as a counting mechanism. Summarized: the waiting time of customer `i` is written to row `i`, column 1 of the Excel file `bank.xls`.

Now set the speed of the simulation to a low rate and reset the simulation. Then start a run and use the task bar to switch from Enterprise Dynamics to the [Excel file](#). If everything went correctly, something 'wonderful' will happen: Parallel to the process in Enterprise Dynamics, the waiting times are written to the first column of `bank.xls`!

Just think about that for a moment: what is possible with *one* bit of data can also be done with a lot more data. This means that it is possible, quite easily, to store large amounts of raw data and write the data to Excel, and subsequently unleash the entire arsenal of available Excel tools.

For those users whose screens shows nothing or merely display a large number of #####. This problem sometimes occurs when the column width is too small for displaying all the data in a specific cell. Making that particular column wider will solve this problem.

For writing throughput times to the second column, the following command can be set on the Trigger on Entry of the Sink: `ExcelActiveX_Write(Input(c), 2, Age(i))`.

Warning: the waiting time of customer 100 is shown in row 100, column 1, but the throughput time of the same customer 100 does not have to be shown in row 100, column 2. Explain why!

Questions and assignments

- In Excel, measure the average waiting and throughput times of the first 1000 customers.

The models with the Excel link can be found under `bank2a.mod` and `bank2b.mod`. The Excel file is named `bank.xls`.

Questions and assignments (For enthusiasts)

- Enter the waiting times of type A customers in column 3, the waiting times of type B customers in column 4, and measure - with sufficient customers - the average waiting time. Do the results correspond with earlier outcomes?

9.4 Reading data from Excel into Enterprise Dynamics

We have succeeded in linking Enterprise Dynamics and Excel and writing output data to Excel but ... reading data from Excel into Enterprise Dynamics is something that also occurs frequently. How this is done is the last subject we shall illustrate now.

In the context of our example, we may well have actually measured customer inter-arrival times available. This arrival pattern is what we want to read into Enterprise Dynamics and use for a simulation run.

Using a formula, generate 100 (positive!) figures in the first and second column of `postoffice.xls`. You can, of course, also use the waiting times that have just been generated ...

In both cases, it is useful to remove the earlier `ExcelActiveX_Write` commands.

In the Source input window under Inter-arrival time, enter the following for type A customers:

```
ExcelActiveX_Read(Output(c)+1,1) and at the Trigger on Exit: Label([servicetime], i) := mins(1)
.
```

For the Trigger on Entry of the Queue write: `if(Output(c) = 100, CloseOutput(c))`.

The `ExcelActiveX_Read(a,b)` command reads the value in cell(`a`,`b`) of the default worksheet of the Excel file, while the `CloseOutput` command ensures that the output of the Source atom shuts down after 100 customers, thereby ending the 'reading-in data process' as well. If this command is not performed, Enterprise Dynamics will continue to read in data and interpret empty cells as an inter-arrival time of 0.

Figure out yourself how the statements for type B customers should read!

The model can be found under the name bank3.mod.

In conclusion: arrival patterns are generated with a Source. For fixed production schedules or timetables, Enterprise Dynamics uses the ArrivalList atom. This atom can also be used for cutting and pasting (large) schedules in the proper format from Excel. The data is then available in an external table, which makes an open link with Excel, at least for data input, superfluous.

Reading data into Enterprise Dynamics through a table results in a significant increase in speed and is therefore highly recommended for most situations!

9.5 To pool or not to pool?

The results of the new post office show something remarkable: the model with a *single* queue (bank1.mod) has a longer average waiting time than the model with *separate* queues (bank2.mod)!

We found the following results:

Average waiting times	single queue (in minutes)	separate queues (in minutes)
type A customers	6.18	2.45
type B customers	6.18	25.7
average of all customers	6.18	4.56

Picture 9-4: Results of simulation runs

How is such a result possible? Aren't we taught all the time that combining means improvement?

After all, in case of separate queues it is quite possible that a queue with type A customers will form in front of the first counter, while the assistant behind the counter for type B customers twiddles thumbs. The answer is: *variation!*

'Combining' reduces average waiting times when there is one type of customers, but not when there are two types of customers, as is the case here.

Without going too deeply into the queuing theory: in the system with separate queues there are two independent M/D/1 models. For that purpose, a set of closed formulas is available for the most important queuing characteristics.

These formulas give the average waiting time (W_q) of type A and type B customers as:

$W_q = 2.5$ minutes and $W_q = 25$ minutes respectively.

The expected average waiting time of all customers therefore is $50/55 \times 2.5 + 5/55 \times 25 = 4.54$ minutes.

In the system with a single queue, a M/G/k system with two customer types is formed. To apply the formulas from the queuing theory we 'merge' the customers into one customer type. They arrive at an average rate of 55 per hour with an expected service time of $E[S] = 50/55 \times 1 + 5/55 \times 10 = 20/11$ or 1.81 minutes.

The variance $\text{Var}[S]$ of this service time is 6.69 and the variance coefficient C, defined as $\text{Var}[S]/(E[S])^2$, is 2.025.

Based on that, the waiting time is roughly - formulas are not given - $W_q = 6.25$ minutes.

The results of our runs pretty much correspond with these theoretical values: *The average waiting time in the separate queues is reduced by 27%!*

The explanation? In separate queues, the irregular customers, whose service time is 10 times longer than that of the regular customers, no longer interrupt the waiting time of the regulars. Even though this results in a considerable increase in the expected waiting time of the irregular customers, the average waiting time of all customers is significantly reduced.

Questions and assignments

- Adapt the separated queue model such that type A customers are allowed to jockey. This means that the first person in the queue for type A customers may use the counter for type B customers, provided there are no type B customers waiting. You can, of course, also experiment with jockeying between both queues.

How does this affect the average waiting time of customers?

10 The Human Resource

In this chapter the Human Resource takes center stage. A Human Resource is a capacity source that is needed on several processing sites and switches between them. Though usually a man of flesh and blood, the Human Resource can also be a piece of equipment. We begin with an example where we need the Human Resource but where the time required for moving up and down between machines is negligible. Subsequently we deal with the different ways in which distances and movement are simulated in Enterprise Dynamics. The example is then expanded with free movement of the Human Resource within the flat grid and along mapped paths.

10.1 Getting started with the Human Resource

Example 5: The Human Resource for Red and Blue

Two semi-finished products, HalfBlue and HalfRed, arrive at two separate but identical production lines. Each production line consists of a drilling machine preceded by a storage facility. Once past the drilling machine, a ten-meter long conveyor transports the products to a CNC machine. From the CNC machine, the products continue to final inspection on a five-meter long conveyor. Here both the red and the blue products are inspected according to the arrival sequence. After that the products leave the system.

The semi-finished products arrive independently of each other with an average inter-arrival time of one hour. Drilling takes 20 minutes on average and the inspection takes an average of 6 minutes. All times follow an exponential distribution.

The CNC machines on the other hand are very constant and have an operating time of 10 minutes.

One operator carries out the final inspection as well as the drilling of both products, which means that the operator is constantly moving up and down between the drilling machines and final inspection. For now, let's assume that these walking times are negligible.

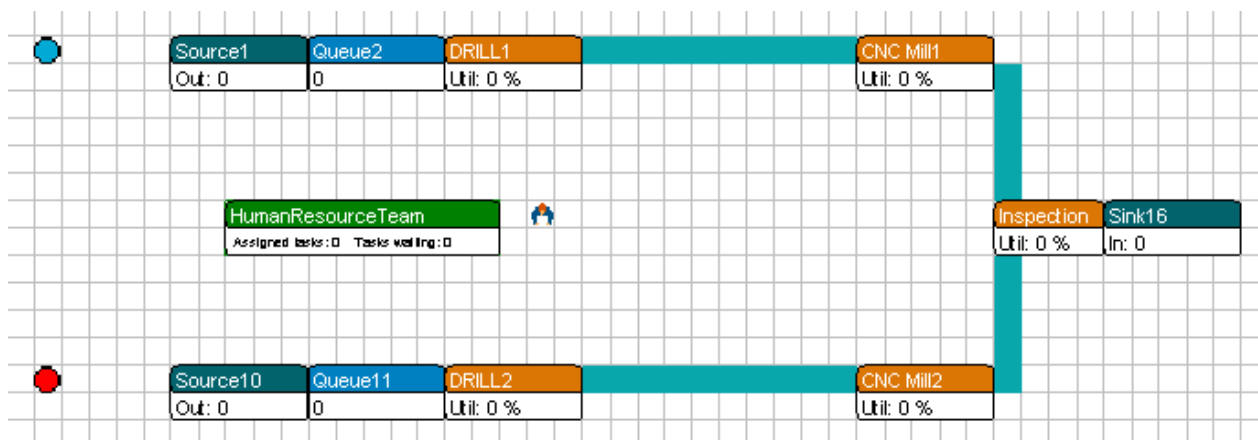

Picture 10-1: Production line for semi-finished products

In Enterprise Dynamics the layout of this production system can be seen in Picture 10-1. Go ahead and build it yourself!

Questions and assignments

1. How high is the (theoretical) utilization rate of the operator?
2. Verify that the utilization level of the drilling machine(s), the CNC machine(s) and inspection (as site) is 33%, 16% and 20% respectively.

Check these results by letting the model run for quite some time: the results you get should roughly look like that!

The processing sites for both drilling and inspection are represented as Servers. These are, after all, operations that take a certain amount of time. Nevertheless, this is insufficient: the layout is right, but you still are left with one person walking between two drilling machines and inspection.

So, the idea is to simply model the sites where the operation takes place in physical terms; in this case as a Server. When a product arrives at the drilling or inspection site, a call goes out for the assistance of a Human Resource. Only when the Human Resource arrives on the scene the operation can start. Once the Human Resource

is no longer needed, it is released.

In Enterprise Dynamics this issue has been solved by means of the Human Resource and the HumanResourceTeam atom. Each Human Resource is part of a team. A team can consist of one or more Human Resources.

Drag a Human Resource and a HumanResourceTeam atom into the model. Both atoms can be found in the library in the Human Resource category. By right-clicking or clicking on the HumanResourceTeam, a window opens, see Picture 10-2.

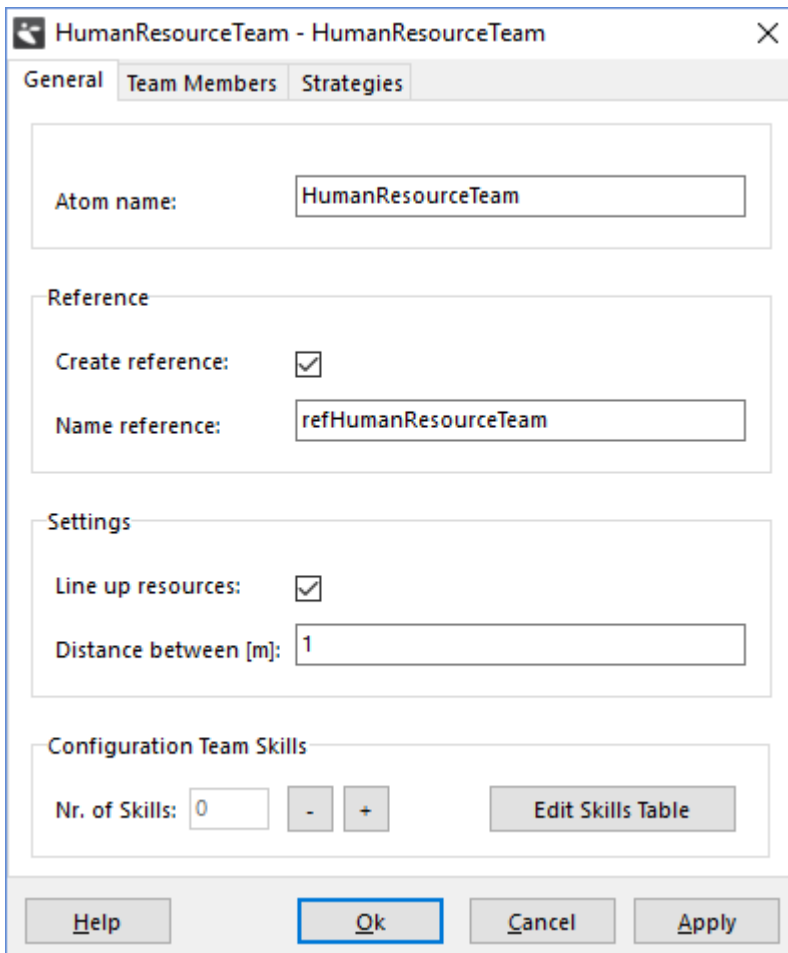

Picture 10-2: Input window for the HumanResourceTeam

Switch to the Team Members page and press the Team Configuration button, a window opens, see Picture 10-3. The table at the top of the team configuration window shows all the teams in your model. There is only one team in the list. Note that the Human Resource is in the table *Not assigned resources*. Push the << button to move the HumanResource to the Team members list. The Human Resource is now part of the HumanResourceTeam. It is very important to create an atom reference to the team, this will make it easy to call and free a resource from this team. Make sure the option *Create reference* on the General page of the HumanResourceTeam is checked. In this case the name of the reference will be `refHumanResourceTeam`. The name has to be unique.

The location of both atoms in the Model Layout, by the way, has no bearing ...

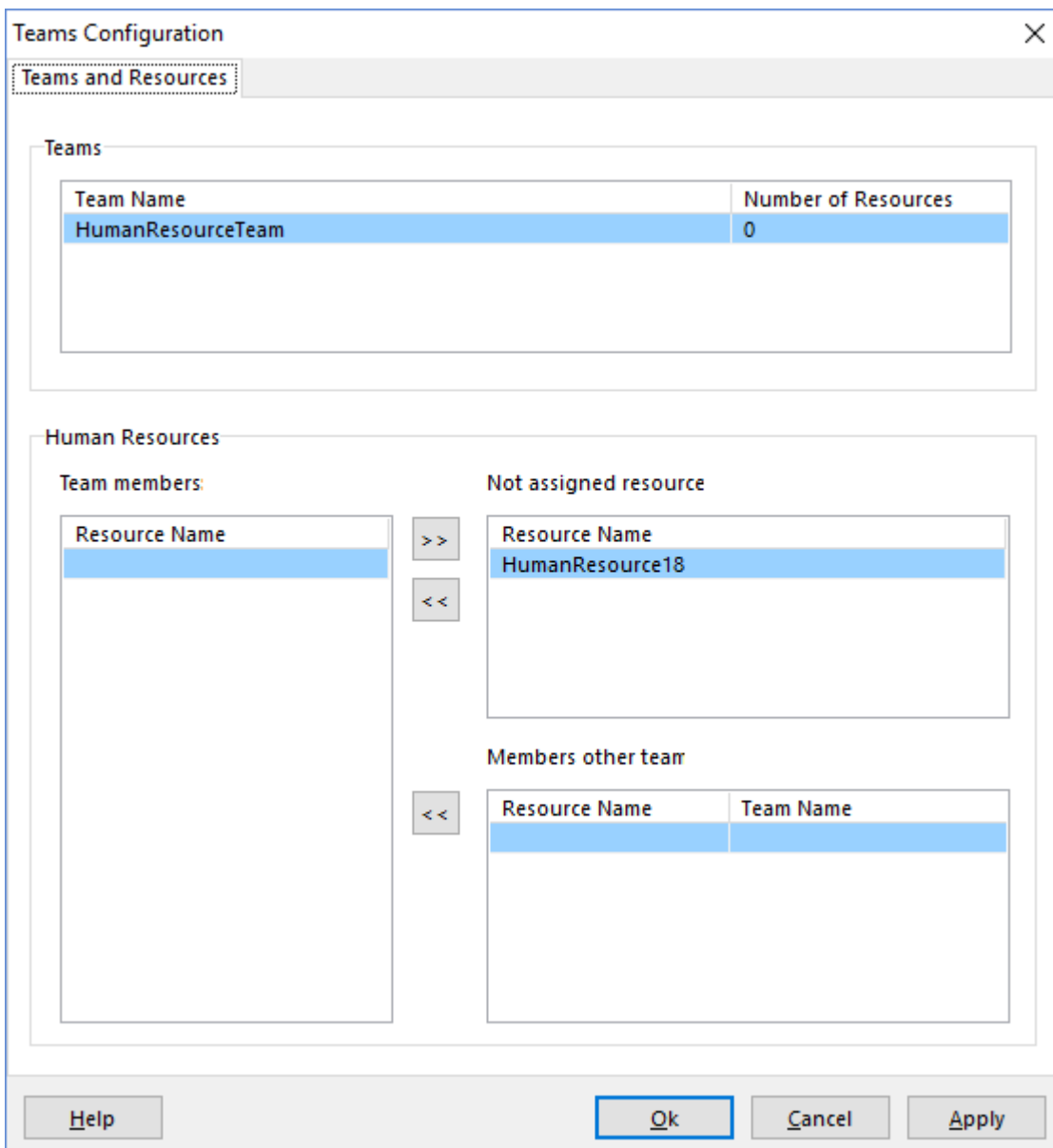

Team Name	Number of Resources
HumanResourceTeam	0

Team members:

Resource Name

Not assigned resource

Resource Name
HumanResource18

Members other team

Resource Name	Team Name

Picture 10-3: Team configuration form

We still have to arrange that the Human Resource is called for inspection and drilling. Since this is necessary on arrival of a product, the obvious thing to do is to set this up in the triggers. The *Trigger on Entry* is executed when a product enters the Server and the *Trigger on Exit* when it leaves. On the triggers of every Server atom you can find a predefined logic to call and free a Human Resource. Select the predefined logics to call and free the Human Resource on the entry and exit trigger of the inspection and drilling atoms. We need the following code on the triggers:

Trigger on Entry: `HumanResourceTeam_CallResources(refHumanResourceTeam, c, i, 1)`

Trigger on Exit: `HumanResourceTeam_FreeResources(refHumanResourceTeam, i)`

The first parameter in the call and free functions should refer to the HumanResourceTeam from which a resource is required. The created reference `refHumanResourceTeam` can be used in these calls. The second parameter of the call function needs to refer to the task location. Since this is on the atom from where the calls are made we can use the atom reference `c`. The same function call can be used on the inspection and drilling atom. If the call is from inspection then `c` will refer to the inspection atom. The third parameter of the call function is a reference to the atom which requires serves. This is the product that entered the task location, thus the reference `i` can be used to refer to this atom. The last parameter states the number of Human Resources that are required for the task.

As both commands play a big role, the full syntax is given here:

HumanResourceTeam_CallResources (e1, e2, e3, e4, {e5, e6})

This command can contain 6 variables; variables 5 and 6 are optional. The following applies:

- e1 reference to the HumanResourceTeam
- e2 reference to the task location
- e3 reference to the served atom
- e4 number of Human Resources required for this task
- e5 value that can be used to define the priority for this task
- e6 the required skill

Example: `HumanResourceTeam_CallResources (refHumanResourceTeam, c, i, 2)` requests 2 Human Resources. The Human Resources are allocated to the served atom typically a product inside the task location. This is often the atom on which this call statement is written. All events on this atom are delayed until the required number of Human Resources is present.

HumanResourceTeam_FreeResources (e1, e2)

- e1 reference to the HumanResourceTeam
- e2 reference to the served atom

Example: `HumanResourceTeam_FreeResources (refHumanResourceTeam, i)` releases all Human Resources from the served atom belonging to the team referenced by `refHumanResourceTeam`.

Open `human Resource1.mod` in the Tutorial Models or correctly adjust the Server atoms in your own model. Run the model and verify that the Human Resource hops constantly from one drilling machine to the other or to the inspection site. Processing sites that want to begin with an operation but have no Human Resource at their disposal, turn red in color!

Every time a call for a Human Resource is made a task is added to the team. By default, the tasks are processed according to their arrival sequence (FIFO). This can lead to the model getting stuck in a so-called deadlock, as a drilling machine can no longer get rid of its products. Make a long simulation run in order to study this situation. Later we will learn how such a deadlock can be prevented.

The utilization rate of the Human Resource can be established during a run by connecting a `StatusMonitor` atom to the Human Resource or with the Experiment Wizard and will be in excess of 80% (Busy status). Does this match your own calculation?

In short; it seems although the model can handle the flow fine, the Human Resource has to work hard even though its walking does not (yet) take time. How to include walking will be discussed in the following section.

10.2 Moving in the model's dimension

The Human Resource can be moved in 3 ways

1. Relocating without time expense (default)
2. Walking
3. Walking along a network

The first option is used when walking times or transport times are negligible in the problem. When using the second option, time used for transport as a consequence of the distance between two locations without worrying about how the route is covered. With the last option, the Human Resource moves over a network of paths and junctions. This is intended for situations such as order pickers in warehouse aisles, but also for vehicles such as forklifts and AGV's, which are simulated in Chapter 11 with Transporters.

The complexity of the behavior of movement clearly increases with option one to three. As a designer of simulation models, always question whether adding transport times and transport networks are relevant within the framework of the problem!

Prior to studying the movement of the Human Resource in more detail, first some more information about distances and the use of dimension in Enterprise Dynamics. The sample models in this tutorial, with the exception of the conveyor in example 4, have so far not made use of the physical dimension. So, what happens, when location, size and distances between places do play a role?

In Picture 10-4, we see the grid - always visible behind the atoms - in addition to a number of other atoms, which we shall deal with later. This grid functions as the grid for coordinates; each square measuring 1 by 1 meter. The visible black square corresponds with the coordinates (0,0) the upper left. This means that Enterprise Dynamics considers the north-eastern corner as reference point for the location of an atom.

Move around with the cursor in Enterprise Dynamics and see the coordinates in the status bar of the Model Layout change in order to get a feel for the coordinate system!

In Picture 10-4, we also see three points, N1-1, N1-2 and N1-3, forming a triangle.

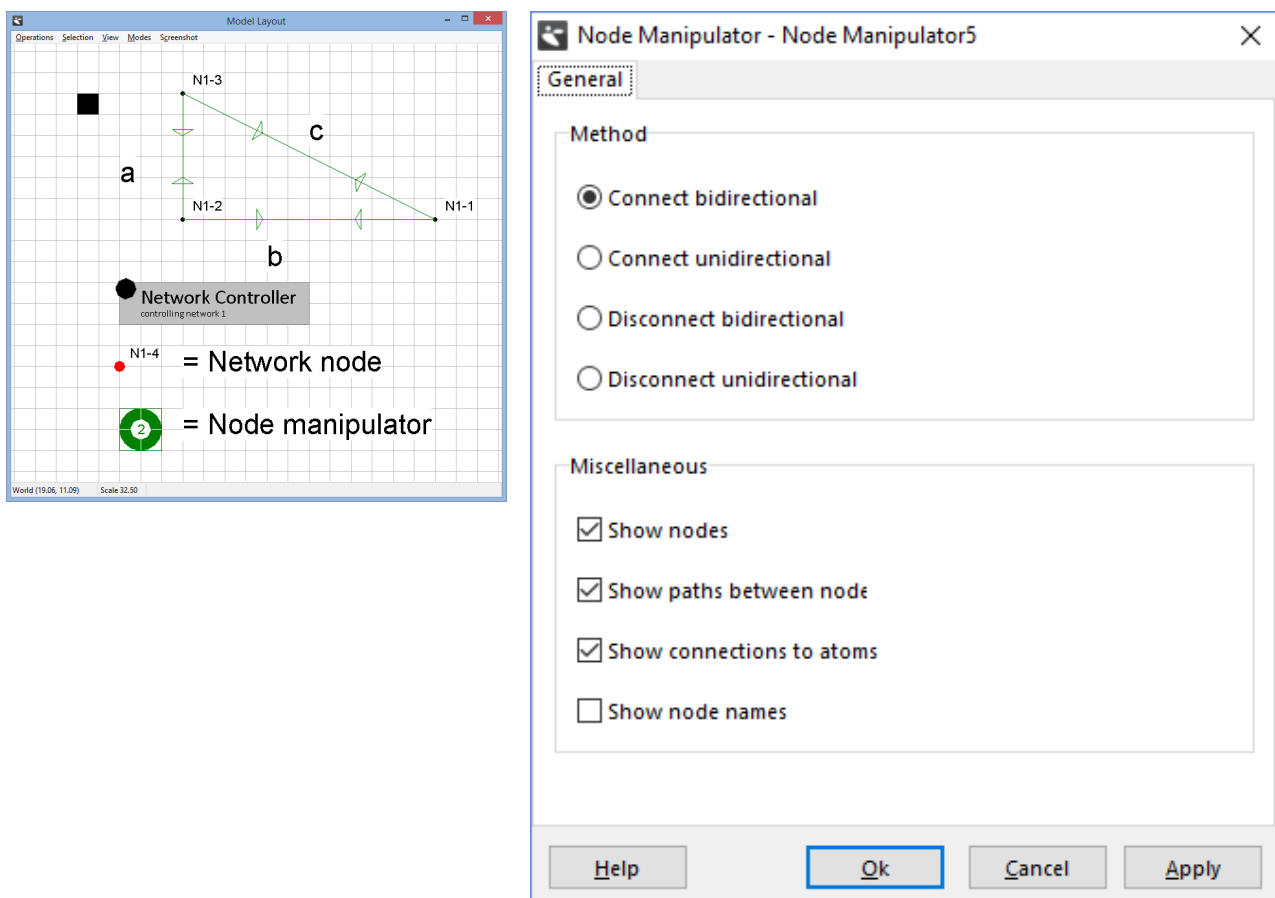

Picture 10-4: Coordinates, distances & several network atoms

The distance between N1-2 and N1-3 is 5 meters, so if a Human Resource moves between these points with a default speed of 1 m/s, it will take him 5 seconds. Pythagoras' theorem applies to distance c: $c^2 = a^2 + b^2$. Verify that $c = 13$!

10.3 Walking Free movement

When distances play a role for the Human Resource, we can change the default setting 'relocate without time expense' to 'walk'.

By right-clicking on the HumanResource the input window appears, see Picture 10-5. Checking the option 'Walk' makes the HumanResource move at a user-definable speed (default is 1 m/s) between his present location and a new location. The distance formula applied is the formula given by Pythagoras, meaning that the distance is determined in a straight line, disregarding any objects in between. This is 'free range' movement.

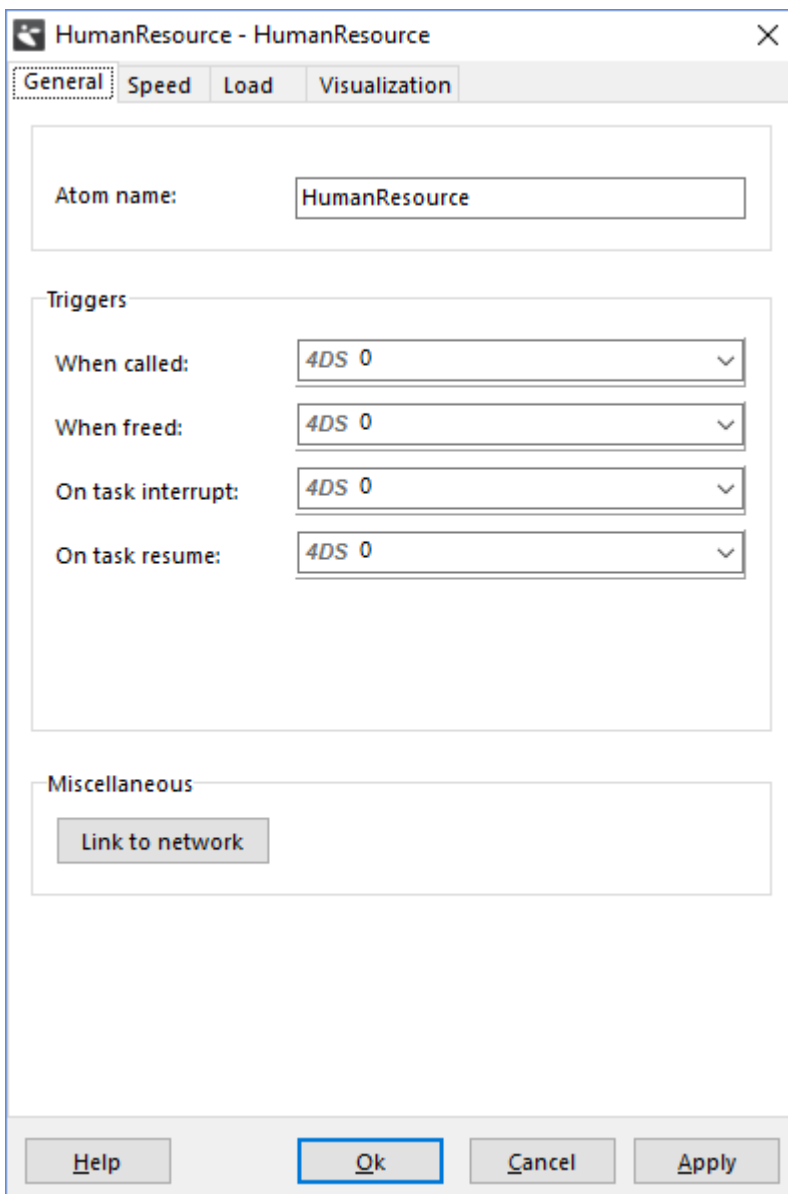

Picture 10-5: Input window for the Human Resource

Attention!

Atoms differ in size. The decisive coordinates are always those of the upper left corner of an atom!

A detailed discussion of the other fields of the Human Resource atom will follow later.

Example 5 (continued): The Human Resource for Red and Blue

Now adapt *human resource1.mod* such that the Human Resource walks as described or open *human resource2.mod*.

Questions and assignments:

Run the model and note that:

3. The Human Resource does indeed move in a direct line from one drilling machine to inspection and vice versa.
4. The animation of the Human Resource at the Server differs from the animation in the previous model.

Calculate and check that the mentioned relocation in the model takes a little less than 21 seconds (√436 seconds, to be exact).

The utilization level of the Human Resource will rise also: on average one hour will be taken up by 40 minutes of drilling, 12 minutes of inspection time, and also by 1 to 2 minutes of walking time. This can be checked with the Experiment Wizard ...

10.4 Networks in general

In the previous chapter we have looked at free-range movement in a straight line. But free-range movement is not always possible due to walls or other obstacles, and so movement often occurs by means of mapped paths.

In Enterprise Dynamics this has led to the concept of a *network*. A network is a collection of points and lines. It is possible to connect Human Resources or Transporters to such a network and once connected they can move through this network only. The points form the junctions in the network; the lines represent the paths. These paths can be used uni- or bi-directionally.

For creating and embedding a network, we proceed along the following steps:

1. Drag a number of **Network Nodes** and a **Node Manipulator** into the Model Layout. Both can be found in the Network category and are shown in Picture 10-4.
2. Connect two selected points by
 - a. placing the Node Manipulator over the first point
 - b. right-clicking (the Node Manipulator turns completely green)
 - c. placing the Node Manipulator over the second point
 - d. right-clicking again

A green link will appear between the 2 points, which depending on the user's selection on the Node Manipulator can be used one-directional or two-directional. Repeat this process for all connections you wish to create.

3. Using the same technique, connect each of the atoms where the Human Resource is needed with a point in the network (placed nearby).
4. Connect the Human Resource with the network by right-clicking, with the cursor on the Human Resource, and selecting Link to network, see Picture 10-5.
5. Drag a **Network Controller** into the Model Layout, (right-)click, and push button Optimize Network.

The names printed in bold refer to new atoms that can all be found under category Network. The Network Node hardly requires explaining. Picture 10-3 shows all options of the Node Manipulator. To delete connections, repeat step 2; this time using the Disconnect option.

If you use *Connect bidirectional* or *Connect unidirectional*, the Node Manipulator turns green, showing 2 or 1 respectively as legend. With *Disconnect bidirectional* or *Disconnect unidirectional*, the Node Manipulator turns red, showing 2 or 1 respectively as legend.

Picture 10-6 contains all options of the Network Controller. Perform exercise 5 in order to familiarize yourself with these atoms, as well as with the steps mentioned above, and read the Help file for these atoms!

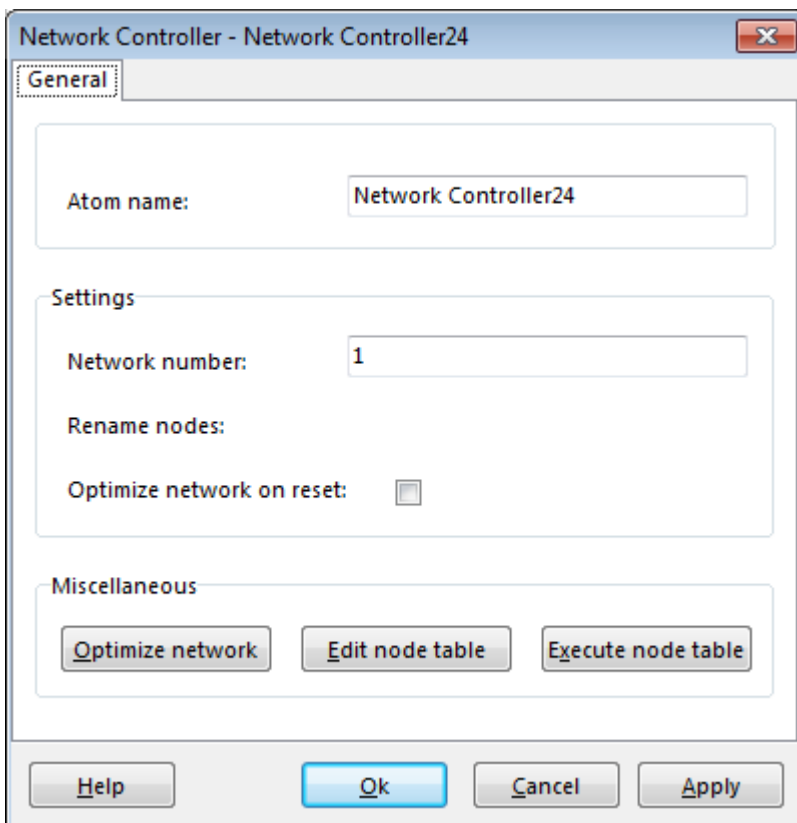

Picture 10-6: Options of the Network Controller

Questions and assignments:

5. Experiment with a new model consisting of a Source, a Server, a network that connects them, and a Conveyor followed by a Sink. Try to add a few one-directional routes, and delete these connections again, etc. Make sure that the shortest route there differs from the way back. Connect the Server and the Conveyor by means of a network. Are blue connection lines showing? Add a HumanResourceTeam with a Human Resource. The Human Resource assists the Server and the Conveyor. Link the Human Resource with the network, as described above. Finally, optimize the network with the Network Controller.

Does the Human Resource move nicely up and down between the various routes?

Important!

Optimize Network with the Network Controller allows users of the network to always take the shortest path (the algorithm of Dijkstra is applied to the internal network). *This is why it is necessary to perform this step after every change made in the network.*

10.5 Walking along a network

Example 5 (continued): The Human Resource for Red and Blue

Add a network with 4 points and 5 connections to the earlier models, as can be seen in Picture 10-7. The blue lines represent the connections between the network and the atoms where the Human Resource is needed. The speed of the Human Resource remains 1 m/s. Perform all steps described in Chapter 10.4 and applied in exercise 5 in a logical manner.

Questions and assignments

6. Verify that the Human Resource walks along the network and picks the shortest route from one location to the next. Note that the Human Resource positions himself at the junction leading to the atom where the Human Resource is called.
7. Verify that walking from the inspection point to a drilling machine takes 23 seconds and that walking between the drilling machines takes 8 seconds. This means that the time needed to walk along the blue connections is not counted!

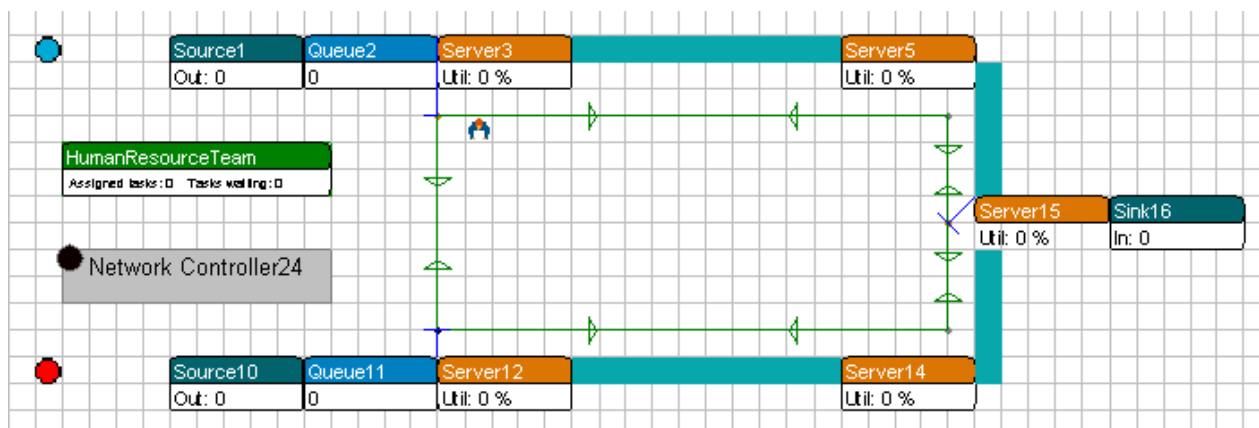

Picture 10-7: The Human Resource in the Network

This model can be found under *human resource3.mod*.

10.6 Allocation of priorities

Those of you who simulate one of these three models long enough will observe that the conveyors occasionally fill up, creating a situation where the Human Resource wants to deliver a product to a conveyor, but can't because the conveyor is full. This is called a *deadlock*: the system hangs because no action is possible anymore.

This situation can occur here as the Human Resource by default processes all requested orders in order of arrival. Let's say that there are queues in front of the drilling machines as well as the inspection point and that the Human Resource is finished at time 100 with assisting in the inspection. Drilling machines 1 and 2 contain a product and have already been 'asking' for a Human Resource for a while: this is evident in visual terms as the atoms turn red in color. Let's assume further that the order reached drilling machine 1 at time 90 and drilling machine 2 at time 95.

What happens now in what sequence at time 100? First, the inspection order is completed (uncoupling of the Human Resource), then a new product is brought to inspection, subsequently the Human Resource checks his list containing three potential orders and, according to the FIFO principle, selects the oldest [longest waiting]. Make sure that this list does not contain *two*, but *three* potential orders. That this is crucial will become clear a little later in the priority rules!

So, if the Human Resource makes a new choice at time 100, his list will show:

Call	From	Time of call
1	Drilling machine 1	90
2	Drilling machine 2	95
3	Inspection	100

Picture 10-8: Call order sequence for the Human Resource without priorities

Based on the FIFO principle the Human Resource now goes to drilling machine 1, then to drilling machine 2 and then back to inspection. So, it is clear that in very busy periods the Human Resource continues to walk around in circles and that the system can deadlock!

We now want to assign priority to the inspection task. The syntax of the call-statement in Chapter 10-1 offers help. On inspection, change the Trigger on Entry:

```
HumanResourceTeam_CallResources(refHumanResourceTeam, c, i, 1)
```

to:

```
HumanResourceTeam_CallResources(refHumanResourceTeam, c, i, 1, 2)
```

The calls from Inspection now have priority 2, while the calls from the drilling machines retain (default) priority 1. A '1' can be added to this last statement, but it is not necessary. We also need to change the task handling strategy on the HumanResourceTeam from FIFO to *By priority descending*. Change the *Sort task by* property of the HumanResourceTeam to *By priority descending*, this setting can be found on the Strategies page of the HumanResourceTeam. If the calls in Picture 10-8 are now sorted by priority first, and only then by time of call, an

entirely different picture emerges:

Call	From	Time of call	Priority
1	Inspection	100	2
2	Drilling machine 1	90	1
3	Drilling machine 2	95	1

Picture 10-9: Call sequence for the Human Resource with priorities

This, in fact, means that the row of inspection orders will be processed first. Why?

Those who want to see this phenomenon in action best take one of the three Human Resource models without priority, watch out for when the model is in danger of deadlocking, stop the run and adjust the priority of the inspection, and then continue the run.

The models with priority are included: *human resource1 with priority.mod*, and so on.

10.7 More Human Resource options

Much more is possible with Human Resources. Imagine a task that requires two Human Resources, e.g. lifting a heavy plate together. A Human Resource can also remain with a product for longer time and follow it through several processes. Certain tasks might require specific skills that not all of the team members have. These possibilities are incorporated in the following assignment.

Questions and assignments

8. Add a second Human Resource to *human resource1.mod* and realize the following:
 - a. Inspection requires 2 Human Resources at the same time.
 - b. Drilling will always require an arbitrary Human Resource, but he will now accompany the product as far as the CNC machine.
 - c. Same as previous; except that Human Resource Red now handles the red products and Human Resource Blue handles the blue products. On the team define 2 skills one to handle red product and blue for the other.

These three modifications together can be found in *human resource4.mod*.

There are even more possibilities with the Human Resources for example a Human Resource sometimes has to transport a product to a different location. In the example models you can find more demonstration of the Human Resource atoms.

11 The Transporter

In practice, the transport of products over distances takes place with forklifts, AGV's, Reach Trucks or other vehicles. In Enterprise Dynamics, these vehicles are simulated with the Transporter or the Advanced Transporter.

The Advanced Transporter can either move freely on the pane or be restricted to paths in a network. This instantly reminds us of the Human Resource described in the previous chapter. In addition, indeed, for the free-range movement of the Advanced Transporter on the pane or movement restricted to paths, we are using the same concepts as for the Human Resource. We therefore advise you to work through Chapter 10 first!

There are *two* Transporters included in the Floorbound group of the Transport category, namely the Transporter and the Advanced Transporter, but only the latter can drive over the paths of a network. In Chapter 11-1 we list the possibilities of both Transporters, followed by an example of the Transporter in Chapter 11-2. In Chapter 11-3 we will first repeat this example for the Advanced Transporter, followed by expanding the subject by adding a network. Chapter 11-4 describes the ideas behind and the connection with the Dispatcher, the Advanced Transporter and the Destinator in more detail. Chapter 11-5, discusses load and unload strategies of the Advanced Transporter, while Chapter 11-6 describes the simultaneous use of several Advanced Transporters.

11.1 Functionalities of the Transporter atoms

Transporters can be used for the following:

1. Moving *one* product from pick-up locations to destinations.
2. *Automatically* determining driving times between pick-up and destination coordinates based on distance and indicated speed (free-range movement without a network).
3. Adding acceleration and deceleration for gathering speed and breaking, while retaining the possibility to automatically determine the correct driving times.
4. Adding unload and load times when picking up and delivering products.

The Advanced Transporter has all the possibilities of the Transporter plus:

5. The capacity to move *several* products simultaneously from pick-up to destination points;
6. The capacity to move by means of the paths of a network, having set the maximum number of vehicles on a connection;
7. The capacity to lift products, to place goods at a certain height onto racks as is customary in warehouses;
8. Allows setting of (x,y,z) coordinates where products can be picked up from or stacked.

11.2 Working with the Transporter

Example 6: Pick-up and delivery

Identical to the situation in example five, we have two parallel production lines where blue or red products, after completion of the machine process, are waiting on the factory floor for a forklift. The forklift transports the product to a conveyor some distance away, at which point the products leave the system. The straight-line distance from the machine to the conveyor behind it is about 15 meters. The distance between both machines is roughly 10 meters. Blue and red products are arriving at the machines with an average inter-arrival time of 2 minutes. The machines have an average production time of 20 seconds. Arrival and production times follow an exponential distribution. All buffers have a standard capacity of 10, the conveyor a standard speed of 1 m/s. The layout of this system can be seen in Picture 11-1.

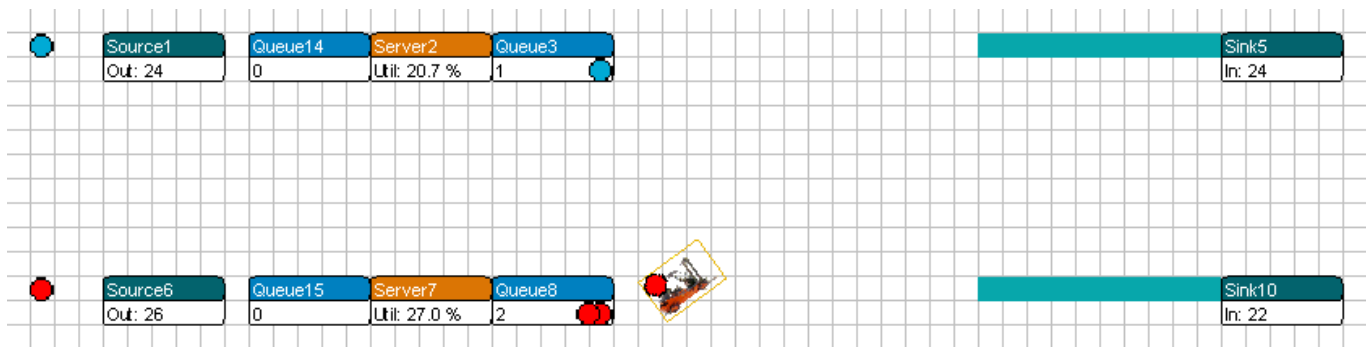

Picture 11-1: Layout of the production line

The forklift has a speed of 1 m/s and free-range movement on the pane. To begin with, let's assume that the products are sent to one of the two conveyors with an equal chance.

Questions and assignments

1. Approximately how high should the forklift's theoretical utilization level be?
2. How high will this utilization level become, when picking up and placing a product takes 5 seconds each?
3. Answer both questions given a situation in which the products are sent to the nearest conveyor only: blue products go to the upper conveyor, red products to the lower conveyor.

Hopefully, it will not be too difficult to answer these questions! Let us now review our answers by building this model with a Transporter.

Drag the Transporter (not the Advanced Transporter!) from the Floorbound group of the Transport category into the model. Connect the Transporter's input channel 1 or 2 respectively with the output channel of the buffer behind the machine of the first or second production line. Connect the Transporter's output channel 1 or 2 respectively with the input channel of the conveyor of the first or second production line. Double clicking on the Transporter opens the input window: see Picture 11-2.

The default setting of the speed is 1 m/s. Change the Send to statement such that products are selected from both conveyors at random. As Input Strategy, select Largest Queue (well visible on the screen) or 'the Longest Waiting'.

Input Strategy and Send to statements are discussed in Chapter 7!

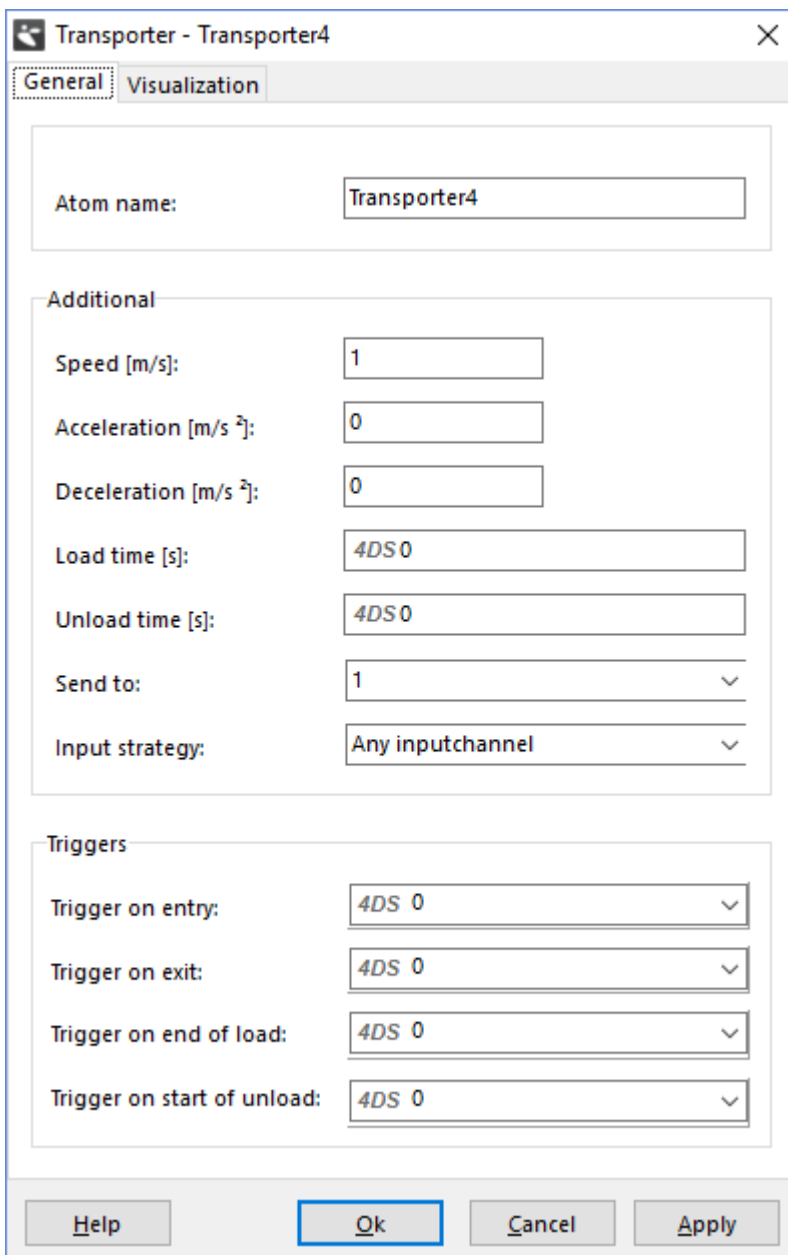

Picture 11-2: Input window of the transporter

Make a few simulation runs with your own model now, or with transporter1.mod. Define 5 8-hour runs in the Experiment Wizard with output variable Status on the Transporter. Do the answers regarding the utilization level match your own calculations?

Then add 5 seconds for loading and unloading on Load Time and Unload Time. Run the experiment again. The utilization level of the forklift will increase from 55% to 71%.

In order to answer question 3, the model will have to be adapted. This can be done very neatly with a label; let's call it 'Destination'. This label is given value 1 for the blue products and value 2 for the red products, and then used on the Transporter's Send to Statement to identify the correct conveyor.

Make a few more runs with your own model or with transporter2.mod. Compared to the previous model, the utilization level will drop by a few percent. This applies both to the variant with unload time as well as to the variant without unload time. Explain why!

11.3 The (Advanced) Transporter in the network

In Chapter 11-1 we claimed that the Advanced Transporter could do everything the Transporter can do. We will therefore, before expanding example 6, first replace the Transporter in model 1 with the Advanced Transporter

and compare the results. These results will naturally have to be the same!

The Advanced Transporter will nearly *always* require two additional atoms: the Dispatcher and the Destinator. Both can be found in the Transport category. The Dispatcher handles the pick-up of the products (to dispatch = send) by means of the Advanced Transporter, the Destinator deals with getting them to their destinations. Picture 11-3 depicts the three atoms in the Model Layout. A different icon for each makes it easy to distinguish between the Advanced Transporter and the Transporter!

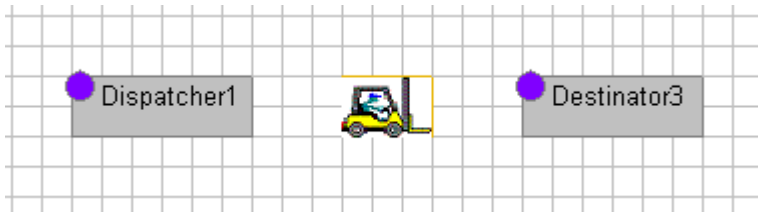

Picture 11-3: The Dispatcher, the Advanced Transporter and the Destinator

The Dispatcher's input channels are linked to the output channels of the pick-up sites, and the output channels are linked with one or more Advanced Transporter(s). The logic of the pick-up process is written on the Dispatcher.

The Destinator's input channels are connected with the output channels of one or more Advanced Transporter(s), and the output channels are linked to the input channels of the destinations. Aside from adjusting channels, not much else takes place on the Destinator.

Therefore, the Advanced Transporter is located in the middle and contains, among other things, the parameters that relate to the subsequent routing, speed, and loading and unloading.

Now go ahead, remove the Transporter from transporter1.mod, and drag the three above-mentioned atoms into the model. Connect the channel in the proper manner. In order to compare the Advanced Transporter with the Transporter, you still have to select the smallest queue from the queue of red and blue products.

Therefore, on the Dispatcher, Sort Tasks By. Select:

3. Content minimum --> atoms in the container with the smallest content are dispatched first.

On the Advanced Transporter under General Parameters, Send to, select:

5. By percentage: 50% of the products go to channel 1, the remaining percentage goes to channel 2

Alternatively, select option 4, where an output channel is chosen at random.

This model can be found under *transporter3.mod* and is portrayed in Picture 11-4.

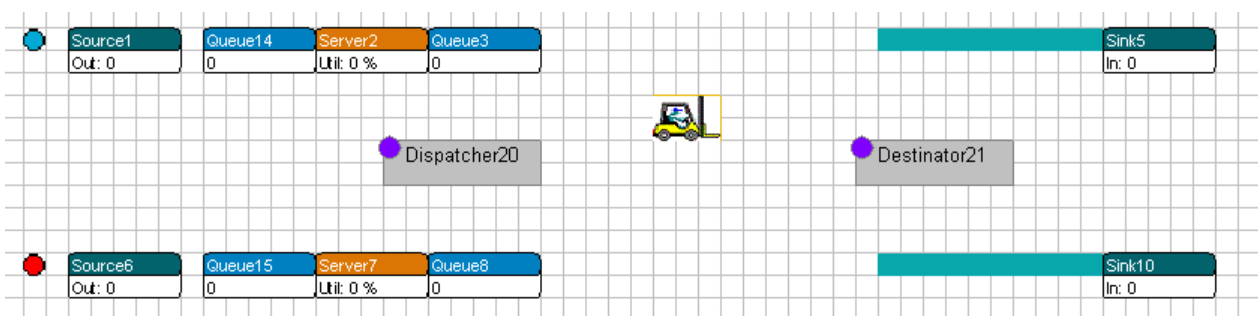

Picture 11-4: The advanced transporter without network

When we run this model, we find, by using the Experiment Wizard, a utilization level of 55% on the Advanced Transporter too.

The following elements pertain to the Advanced Transporter only. Since this is clear from the context, we will drop the prefix 'advanced'.

Example 6 (first continuation)

The production lines and the running conveyors appear to be located in two different halls of the factory. A path connects both halls and the movement in each of the halls proceeds by way of mapped paths as shown in Picture 11-5.

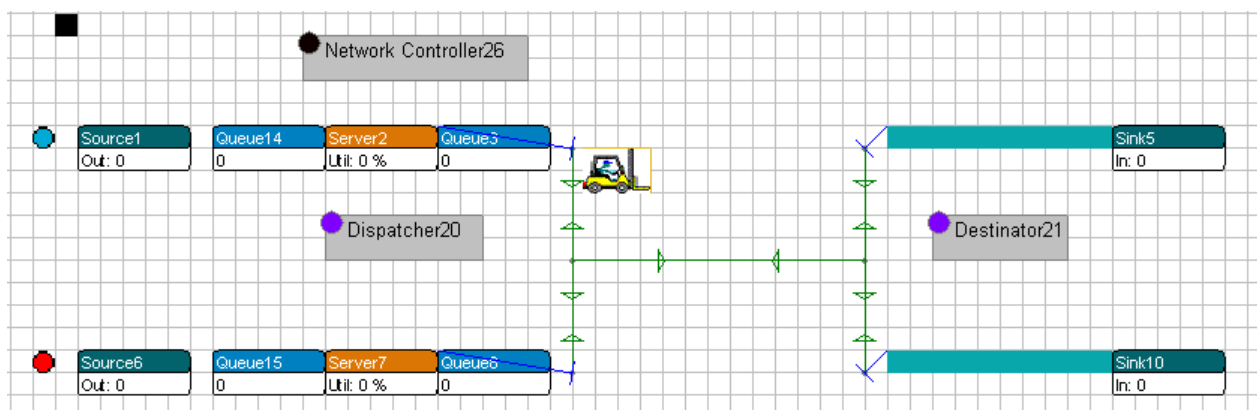

Picture 11-5: The advanced transporter in a network

Two points are connected with a pick-up site at the end of a production line, 2 points are connected with a destination site for a running conveyor, and two points form the end points of the path between the two halls. All connections can be used bi-directional.

Questions and assignments

4. Using transporter3.mod as basis, add the above network with 6 points.
5. How high is the utilization level of the Transporter then?
6. How high is the utilization level when adding 5 seconds for loading and unloading?

Important!

Always use the steps described in Chapter 10 for building a network. Start by connecting the Transporter to the network before optimizing the network!

First, check if the model works, as it should on the screen. Does the Transporter move along the connections? Are the transport times correct? When in doubt, use *transporter4.mod*!

If everything works out, the answer to question 2 will show a utilization level of 77%, given that one up-and-down cycle takes 46 seconds. On average, a product enters a buffer once every minute: $46/60$ rounded is 77%. With loading and unloading taking 5 seconds, we add 10 seconds to the cycle time: the utilization level rises to $56/60$ or 93%.

11.4 The connection between Dispatcher, Advanced Transporter and Destinator

Example 6 has helped to demonstrate a number of the properties of both these Transporters. The 'basic' Transporter is discussed in full. Acceleration and deceleration are all that has been skipped but is easily built into the model - for both Transporters - and watched on the screen. What's more, we showed how the Advanced Transporter moves by means of a network. But ... so much more is possible with this atom!

First, we shall describe the Dispatcher and Destinator in greater detail. Both can be used only in combination with the Advanced Transporter.

The Dispatcher

The Dispatcher generates transport tasks (no products!) for the atoms connected to the input channels of the Dispatcher. These tasks are allocated to the Advanced Transporters attached to the output channels of the Dispatcher: this means there can be more than one!

There are several *Dispatch To* rules, with as default: 1. Specific channel --> always send to channel 1. This is the Transporter attached to the first output channel of the Dispatcher.

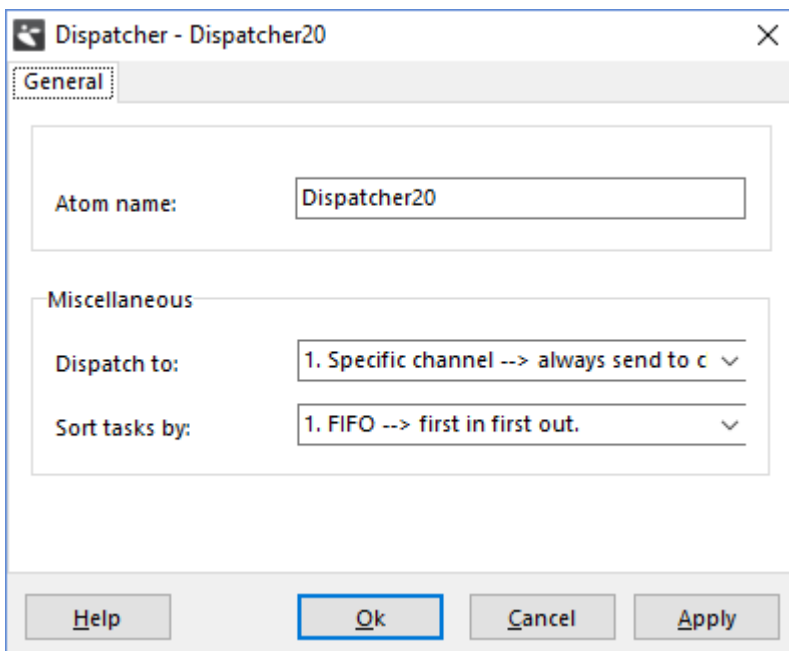

Picture 11-6: The Input window for the Dispatcher

These transport tasks can be sorted ('Sort tasks by') according to 10 pre-defined sorting rules, with FIFO as default. Study all pre-defined allocation and sorting rules!

The Destinator

The input channels of the Destinator are linked to the output channels of one or more Advanced Transporters. The output channels of the Destinator are linked to all possible destination sites. Since all the logic of delivering is placed on the Advanced Transporter, not much else is to be seen in the Destinator window, see Picture 11-7.

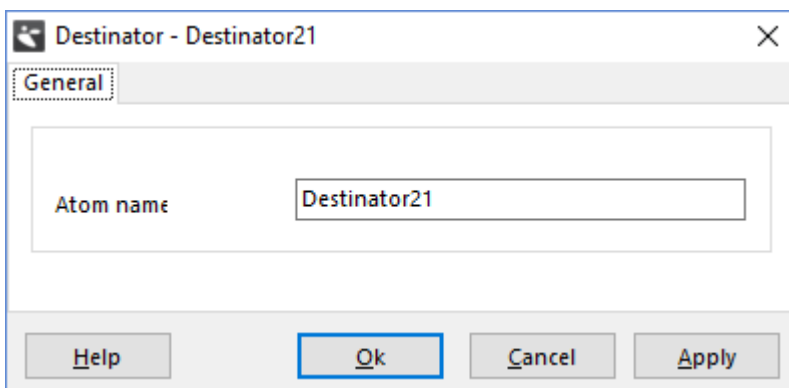

Picture 11-7: The Input window for the Destinator

The Advanced Transporter

The input window of the Advanced Transporter has six different tab sheets in which parameters can be set:

- General parameters
- Speed parameters
- Load parameters
- Offset parameters
- Battery parameters
- Visualization

Here, we will discuss the General Parameters and the Load Parameters. The Speed Parameters are self explanatory. The Offset Parameters will be dealt with in a later chapter, together with the Warehouse Atom.

The General Parameters show no new functionality, see Picture 11-8. However, it is important to know that the Send to Statement is performed via the output channels of the Destinator.

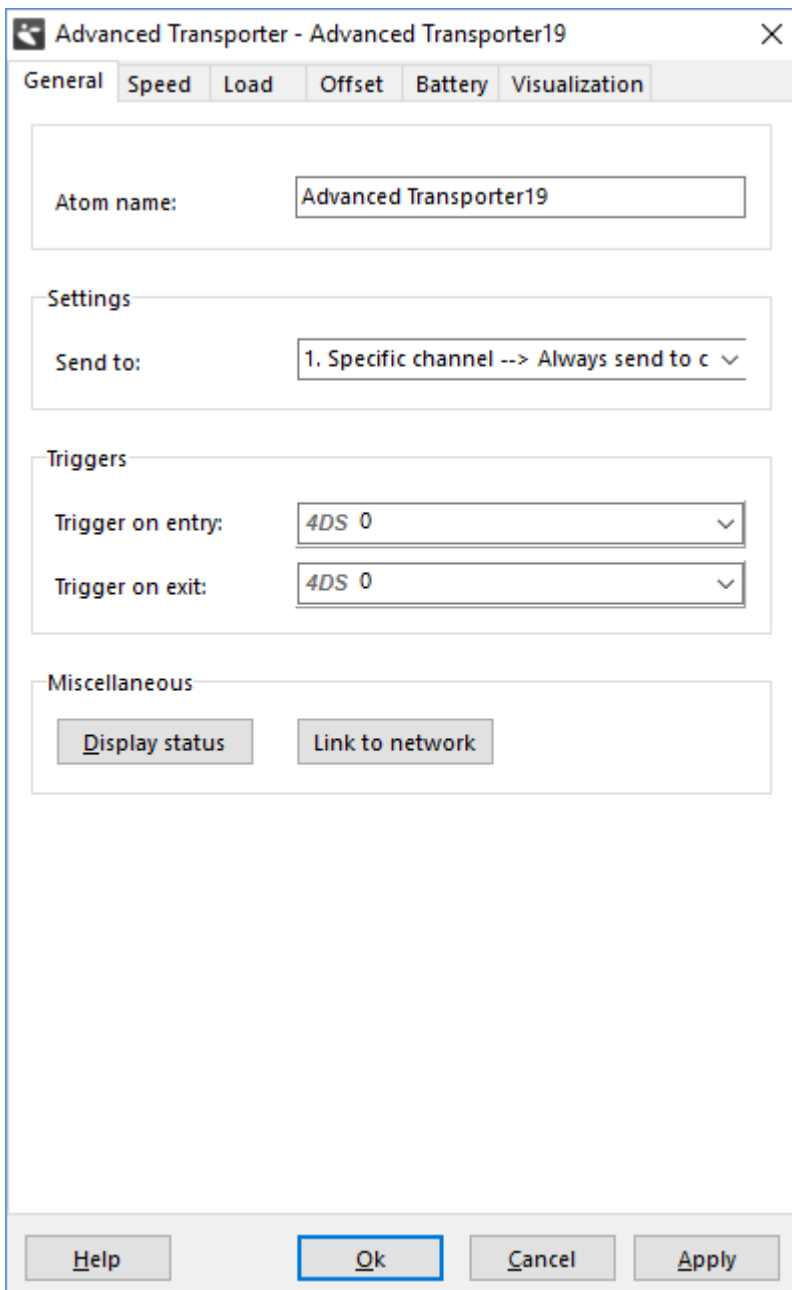

Picture 11-8: The Input window of the Advanced Transporter

The Load Parameters however, do offer many new options, see Picture 11-9. First of all, it is possible to adjust the load quantity. Only when that quantity has been picked up, the Transporter will start transporting products!

When no load restrictions are set, loading will take place based on the arrival sequence of the transport tasks, meaning that the Transporter may be running up and down between load sites. Six settings are possible:

- No restriction (default)
- Same name
- Same label value
- Same label text
- Same container
- Same mother

We will explain some of these options.

The *load quantity* with the corresponding *restriction* only becomes active after the first product is loaded. Let's say, for example, we have a *load quantity* of 5 and a Transporter makes a transport that first takes him to a product named `radio` in Queue10.

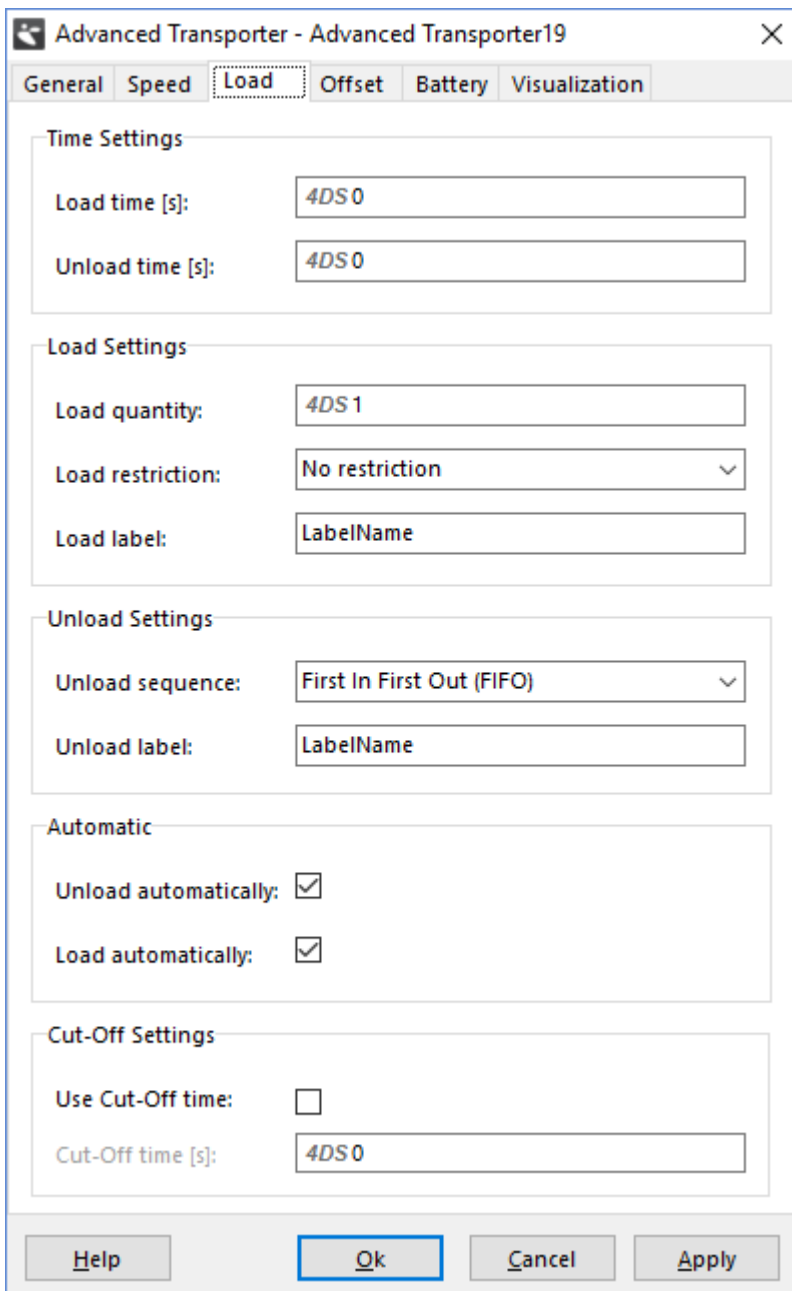

Picture 11-9: Load parameters of the Advanced Transporter

Then the *Load restriction*:

- Same name leads to waiting and collecting another 4 radios from all pick-up sites;
- Same container leads to waiting and picking up another 4 radios from Queue10.

In both of these situations, the products named 'radio' must still be able to appear; so, watch out for deadlocks!

11.5 Load and unload strategies of the Advanced Transporter

Let's build the following options into our example problem:

1. Collecting and transporting two products to the conveyors;
2. Collecting and transporting two *identical* products to the conveyors;
3. Collecting and transporting two *identical* products to a specific conveyor: the blue products to the first conveyor, the red products to the second conveyor.

Option 1 is easy to realize: change the load quantity to 2. Verify that the Transporter is now transporting both

red-blue as well as any other product combination, depending on their arrival sequence in the buffers.

More specific, when a blue product follows a red product, the Transporter will move to red only after the red product has arrived in the buffer. Subsequently the Transporter will move to the blue product, possibly after waiting and then to the conveyors. Note that the last product, which was picked up, appears in the icon of the Advanced Transporter.

Unloading also has many variants: red and blue placed on the same conveyor and on different conveyors. This was the idea of option 1 as well, but why does it take place the way it does?

The answer lies in the *Send to Statement*: a product will go to the first conveyor with a 50% chance or will go to the second conveyor with the same probability. Evidently, some kind of draw goes on for each product inside the buffer, establishing the 'preferred' conveyor. Option 1 can be seen in *transporter5a.mod*.

For option 2, all that we do is change the *Load Restriction to Same Container* from option 1. This process can be seen in *transporter5b.mod*. Delivery still occurs in an unstructured way.

For Option 3, we revert to the 'destination' label as we have done before in Chapter 11-2: blue products receive a 'destination' label with value 1, red products receive a 'destination' label with value 2. Then, from Option 2, adjust the *Send to Statement* on the Transporter: 7. By label value (direct): Use the value stored in the Label named Destination and send to the corresponding channel. This solution can be found in *transporter5c.mod*.

Come up with alternative questions yourself and try to solve them...

11.6 The use of several Transporters

Several (advanced) Transporters with different properties on the same network: how does that work? And what if they are not allowed to overtake? Let's examine these problems again by means of our example.

Example 6 (second continuation)

Due to the high customer demand the production flow of both product lines has doubled. Our one Transporter cannot handle this flow and a second Transporter has been acquired. Both Transporters are still transporting one product at a time to an arbitrarily selected conveyor; however, the second Transporter is significantly faster and has a speed of 2 m/s. When both Transporters are free to pick up a product, the product is collected by the faster Transporter.

Questions and assignments

7. Using *transporter4.mod* as basis, add a second Transporter to the network with the required properties and adjust the product supply. Don't forget to optimize the network!
8. Study the behavior of both Transporters in your own model or, when in doubt, open *transporter6.mod*. Can Transporter 1 overtake Transporter 2 without problems?
9. In order to check things, answer the questions concerning the utilization levels of both Transporters again.

In *transporter6.mod*, we have added a second Advanced Transporter to the network. To keep them apart, the icon of the second Transporter has been changed into the icon of the 'normal' Transporter. That of course does not change the functionality of our new Advanced Transporter! Picture 11-10 shows a section of the layout with both Transporters.

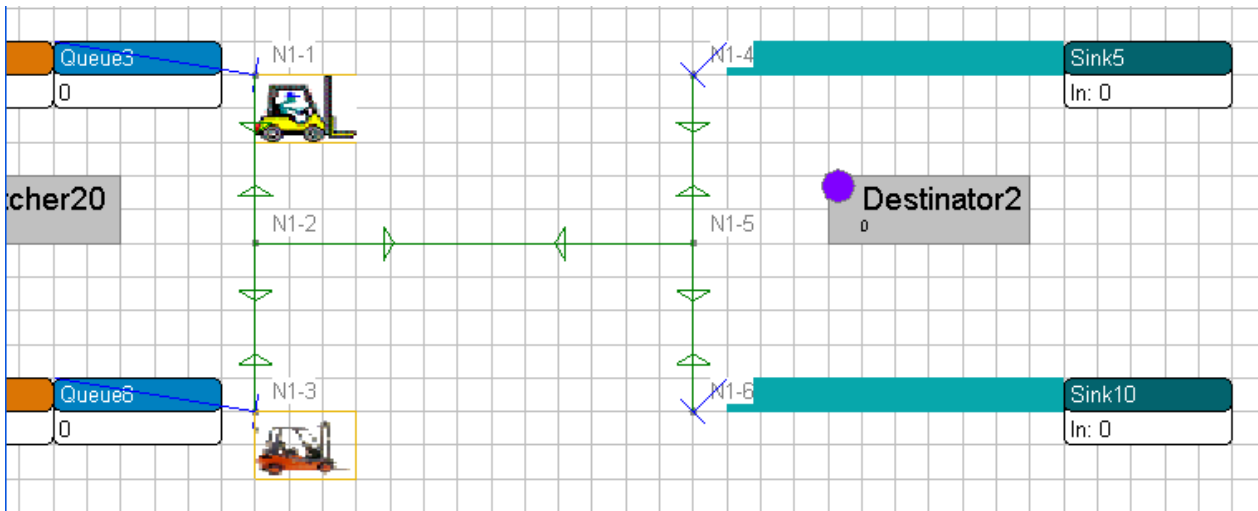

Picture 11-10: Two transporters in one network

With the Node Manipulator and the Show Nodes option, the names of the nodes are made visible. As home base for the yellow and red Transporter, node N1-1 or N1-3 respectively were selected. These adjustments can be seen when the model is reset.

The allocation of a product to the fast Transporter, when both Transporters are free, is done on the Dispatcher with Dispatch to:

3. A free Transporter (LTF) --> look for a free Transporter. Check the Last Transporter connected to the dispatcher First.

This is done because the fast Transporter is connected to the second output channel of the Dispatcher. Study the other Dispatch To rules in order to get an idea of the possibilities.

Question 9 is answered with the Experiment Wizard. With priority given to Transporter 2, we observed a utilization level of 48% (Status Idle 0.52) for the Transporters as a group, while the utilization level for Transporter 1 with priority rises to 56% (Status Idle 0.44).

With an equal distribution of the load, this works out in theory at 57.5%: 2 orders per minute, one of which is carried out by Transporter 1 (46 seconds) and one by Transporter 2 (23 seconds). This comes to an average of 34.5 seconds work out of 60 seconds.

Find an explanation why these 57.5% are still higher than the measured 56% with priority for the slow Transporter!

Example 6 (third continuation)

Due to security considerations, only one Transporter may use the center aisle path in both directions. A second Transporter has to wait until the respective lane is free again. Overtaking on this stretch therefore is impossible.

Questions and assignments

10. Realize the above situation with the two Transporters in the network.

In order to answer question 10, we examine how we can realize capacity restrictions on sections of a network: In Picture 11-11, we see 2 Transporters moving on the connection N1-2 to N1-5, a situation that now must be ruled out.

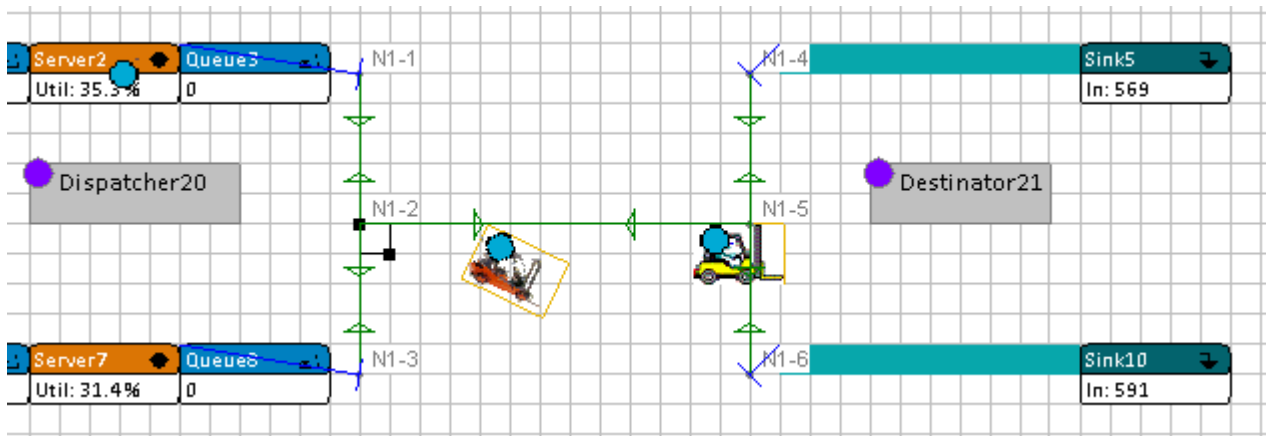

Picture 11-11: Two transporters on the connection N1-2 to N1-5

Furthermore, point N1-2 has been selected. This is evident from the black border to the lower right of N1-2. Double clicking on that point opens the table of Picture 11-12.

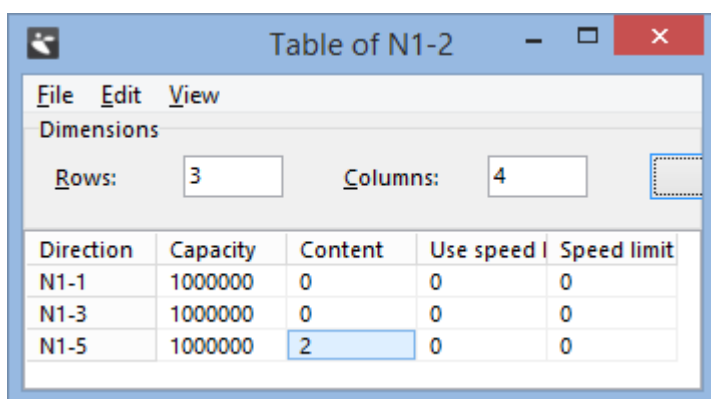

Direction	Capacity	Content	Use speed	Speed limit
N1-1	1000000	0	0	0
N1-3	1000000	0	0	0
N1-5	1000000	2	0	0

Picture 11-12: The network table of N1-2

This table contains the three connections from N1-2 to N1-1, N1-3 and N1-5. *Capacity* shows the permitted number of vehicles allowed to move simultaneously on the indicated connection. The default setting is 1000000, or better still: infinite. *Content* indicates how many vehicles are moving on the indicated connection at that moment. The content of 2 vehicles from N1-2 to N1-5 is part of the snapshot in Picture 11-11.

Let the model run for a while to see how the numbers in the right-hand column of Picture 11-12 continuously keep changing. Examine this behavior at the other points of the network also.

By changing the capacity from N1-2 to N1-5 to 1, answering question 11 now has become easy. Do the same from N1-5 to N1-2!

Now study how the Transporters behave on the stretch from N1-2 to N1-5. Are the vehicles waiting for each other? Note that the connections turn red when the capacity limit is reached! This model can be found under *transporter7.mod*.

For now, we stop explaining the application of Transporters with or without network for the time being.

We are now able to model several complex problems in warehouse environments.